

FLYING ACES

Club News

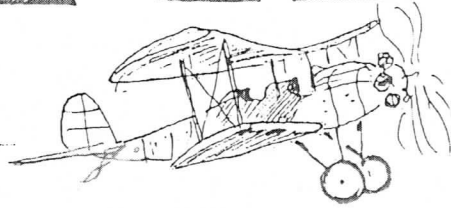

ISSUE #243-168 July/August 2008

#242-168



I start this on the eve of the FAC NATS MK XVI. That's thirty years of hobby fellowship under the command of Col. Lin Reichel. As I write, I keep in mind that some of the FAC family may not have yet learned about Lin's passing on June sixteenth.

With the onset of Lin's illness, the GHQ Council set into motion a plan that Lin helped create several years ago to insure that the FAC would continue without skipping a beat. As a result of his foresight and the Council's response to duty--I am the new Commander in Chief. I thank the Council for the trust they place in me. I will count on their advice and support. I welcome the opportunity to be in this position: the voice of our family. I expect all of you to continue being the heart of the FAC.

Lin had a leadership style second to none. What's my style? We'll learn soon enough. What's my agenda? I want to insure that the heart rhythm of the FAC doesn't skip a beat. To accomplish that, I plan on getting more of you involved with GHQ: especially the Council. The Members at Large program will be expanded; however, I will refer to these members as "Council Consultants."

The news letter is the blood line of the FAC. I have asked Juanita to take over as the editor. As such she will also be in charge of membership and renewals. When renewing, please add your email address. As of August first, Mike Welshans will become the Keeper of Kanones. Please send all Kanone Reports to Mike at 976 Pearson, Ferndale, MI 48220-3118.

And now I write on the eve of the first FAC NEWS without Lin. I congratulate Juanita for a job well done. Although the bulk of this issue is results of the NATS, I remind you to keep those contributions coming in for future issues.

Speaking of the NATS...to all who where there, I truly hope you had an enjoyable experience. I personally thank each of you who helped in any way to ensure another successful event. Admittedly, a few mistakes were made and those individuals involved have been notified with a personal apology. We will do better next time.

There were so many of you came from hundreds and thousands of miles away at great expense. As the young say, "You guys rock!" There were members from the west coast, Canada, and England. And for the very first time, two members came from Brisbane, Australia! I thank Christina Hansson and Maurice Taudevin for making such an odyssey and the donation of the Australian flag which will fly over GHQ at all future NATS.

In closing I must make a few remarks about my mentor. I had the honor of giving the FAC eulogy at Lin's funeral. I quote myself, "Lin received many accolades from the model airplane community. His memory will never fade. Every time someone in the FAC family builds a stick and tissue model it will be a tribute to Lin. Every time someone launches their model it will be an honor to Lin. And every time one of our models rises up toward the clouds...just off its wing tip...Lin's legacy will soar right along with it."

Wishing you blue skies and gentle thermals, Ross P. Mayo, CinC, FAC.



**NOTES FROM THE 2008 FAC NATS MARK XVI
30th ANNIVERSARY EVENT**

GRAND CHAMPIONS

SCALE...TOM HALLMAN

NON-SCALE...DON DeLOACH

EARL STAHL AWARD for most outstanding scale model.....the Junker J1 by **TOM HALLMAN**.
WALT MOONEY AWARD for best Peanut model.....the Potez 29-2 by **RICH WEBER**.
COLE PALEN AWARD for winner of WWI Combat.....the Grain Kitten by **STU WECKERLY**.
EARL VAN GORDER MEMORIAL TROPHY for outstanding WWII mode..the KI-61 TONY by **MIKE ISERMANN**.
CATS ASS TROPHY...for completely rebuilding an illegal model from the 2007 event that no one claimed only to throw a box on top of it in the big white truck.....**SAL CERRIE**.
ANGUS McSCHADENFUEHER AWARD for the best HIGH WING CABIN MODEL flown in FAC SCALE with 3 MAXES and 60 scale points.....the VEGA by **DAVE MITCHELL**.
BOB THOMPSON FICTION FLYER AWARD.....the Ace McCoy trainer by **JOHN STOTT**.
VIC DIDELOT FAC SPIRIT AWARD.....**COL. LIN REICHEL**.
NEW! THE LIN REICHEL MEMORIAL MENTOR AWARD.....**PRES BRUNING**.

FOUNDING FATHER'S AWARD

PEANUT SCALE...GREGG WEST

FAC RUBBER SCALE...BERNARD DION

HALL OF FAME INDUCTEES FOR 2008

DIANE AND ROY COURTNEY

JIM FIORELLO

STEW MEYERS

DENNIS NORMAN

A FEW STATS FROM THE CONTEST

39 EVENTS 135 CONTESTANTS 1,029 TIMED FLIGHTS 129 MAXES 396 MASS LAUNCH FLIGHTS

BLUE MAX AWARDS

**ROY DIVIS
JIM HYKA**

**JOHN HUTCHINSON
DAVE MITCHEL**

**TIM LAVENDER
MARK RZADCA**

**PETE KAITERIS
GEORGE WHITE**

MILE STONES

100 VICTORIES...JOHN STOTT and WALLY FARRELL

300 VICTORIES...JACK McGILLIVRAY

MEMBERS WHO HAVE BEEN TO EACH OF THE SIXTEEN FAC NATS

ROSS P. MAYO

JACK MOSES

FERNANDO RAMOS

JUANITA REICHEL

JOHN STOTT

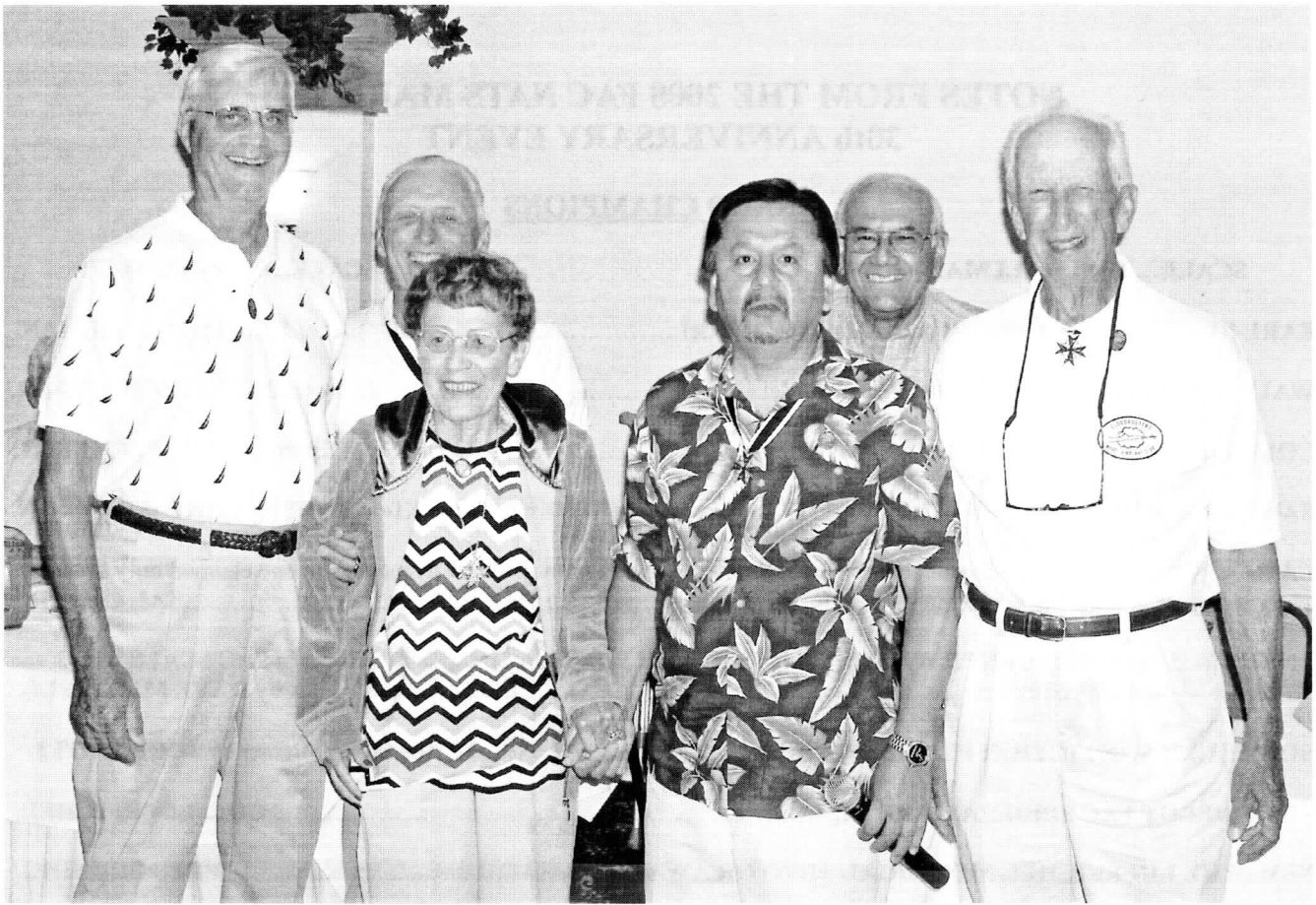

**Those who have been at all sixteen Nats.
Ray Rakow, John Stott, Juanita Reichel, Ross Mayo, Fernando Ramos, and Jack
Moses.**



AWARDS
**Pete Kaiteris, Dave Mitchell, Tom Hallman, Don DeLoach, Dave Stott, Rich Weber,
Mike Isserman**

FAC PEANUT SCALE							BEST		
Contestant	Plane	FLT. # 1	FLT. # 2	FLT. # 3	SCALE SCORE	BONUS POINTS	TIME FAC"D	TOTAL	PLACE
Gene Smith	Tigercat	74	35	38	49	30	67	146	1
Tom Hallman	Martinsyde Buzzard	85			58	15	72.5	145.5	2
Tom Nallen II	Bebe Jodel D9	93	120	92	52	10	82.5	144.5	3
Don DeLoach	Keith Rider R-6	43	68	117	52	10	81.75	143.75	4
Rich Weber	Potez 29-2	35	63		60.5	15	61.5	137	5
Mike Issermann	Maboussin	80	70		52	15	70	137	
Jeff Runnels	ME 109	88	101	57	48	10	77.75	135.75	
Paul Boyanowski	WACO ZGC-7	32	23	70	53	15	65	133	
Marcy Green	Tiger Moth	72	41	61	52	15	66	133	
Jim Miller	DH-6	75			49	15	67.5	131.5	
Jack Kacian	Culver Dart	53	47	54	60	10	54	124	
Dallas Cornelious	Chambermaid R-1	70	66	71	53	5	65.5	123.5	
Richard Zapf	Vickers Supermarine	55			50	15	55	120	
Jim Hemmel	Chambermaid R-1	55	43	41	53	5	55	113	
Paul Stott	Druine Turbulent	34	23	47	55	10	47	112	
Mike Stuart	Laird Speedwing Jr.	33			57	15	33	105	
Jim Miller	Lemberger LD 20B	21	21		53	15	21	89	

GHQ PEANUT SCALE					(A)	(B)	(C)		
Contestant	Plane	FLT. # 1	FLT. # 2	FLT. # 3	3 FLT TOTAL	SCALE SCORE	B x's 26	A + C	PLACE
Al Lawton	Folkerts SK-3	80	94	93	267	11	286	553	1
Tom Nallen II	Turner T-40	90	64	78	232	12	312	544	2
Walt Farrell	Floyd Bean	70	68	120	258	10	260	518	3
John Stott	Prest Baby	75	45	64	184	12	312	496	4
John Houck	Druine Turbulent	47	38	25	110	10	260	370	5
Jeff Runnels	Mooney Mite	41	120		161	8	208	369	

FAC HI-WING PEANUT SCALE						BEST		
Contestant	Plane	FLT. # 1	FLT. # 2	FLT. # 3	SCALE SCORE	TIME FAC"D	TOTAL	PLACE
Jeff Runnels	Nesmith Cougar	120	51	46	62.5	82.5	145	1
Gene Smith	Piper Colt	114	81	106	59	81	140	2
Tom Hallman	Clipped Wing Cub	83	80		62.5	71.5	134	3
Dallas Cornelious	Lacey M-10	42	94	54	55	76	131	4
Mike Isserman	Big X	45	52	65	62.5	62.5	125	5
John Houck	SD-1A	54	64		62	62	124	
Jeff Runnels	Cessna Cardinal	67	54	84	51	72	123	
Jerry Crawmer	Lacey M-10	58			61	58	119	
Chris Boehm	O' Ironsides	66	37	48	52	63	115	
Wally Farrell	Piper Cub	56	43	50	56	56	112	
Ed Pelatowski	Wittman Tailwing	28	21	39	50	39	89	

WW II COMBAT		
	4 Rounds	
Contestant	Plane	Place
Jim DeTar	Curtiss SBC Helldiver	1
Dick Gorman	Messerschmitt Bf 109	2
Pat Murray	Grumman TBF Avenge	3
Mike Isserman	Kowasaki Ki-61 "Tony"	4
Luc Martin	Kowasaki Ki-61 "Tony"	5
Bernard Dion	Aichi D3A "Val"	
Richard Zapf	Bell P-39 Airacobra	
Mark Fineman	Bell P-63 A Kingcobra	
Walt Farrell	Bell P-63 A Kingcobra	
Stew Meyers	Boulton Paul P.82 Defiant	
Ara Dedekian	Brewster Buffalo	
Tom Arnold	Dornier Do 335	
Andrew Ricci	Fairey Barracuda	
Roger Willis	Fairey Barracuda	
George Mansfield	Fairey Barracuda	
Jack McGillivray	Fairey Battle	
Chris Starleaf	Fiat G-50	
Paul Stott	Fiat G-55	
Doug Beardsworth	Grumman F4F Wildcat	
Jeff Runnels	Grumman F6F Hellcat	
Claud Powell	Hawker Hurricane	
Dave Mitchell	Hawker Tempest II	
Jack Kacian	Hawker Typhoon	
Bill Mueffelmann	Heinkel 100 D	
John Donelson	Kowasaki Ki-61 "Tony"	
George White	Kowasaki Ki-61 "Tony"	
Dallas Cornelius	Kowasaki Ki-61 "Tony"	
Don DeLoach	Kowasaki Ki-61 "Tony"	
Gene Smith	Kowasaki Ki-61 "Tony"	
Orv Olm	Messerschmitt Bf 109	
Jim Hemmel	Messerschmitt Bf 109	
Lindsey Smith	Mikoyan-Gurevich MIG-3	
Rich Miller	North American P-51D Mustang	
Doug Griggs	Republic P-40 Q	
Maurice Toudevin	Severski P-35	
Ronny Gosselin	Supermarine Spitfire	
Greg West	TBY Seawolf	
Clive Gamble	Westland Welkin	
Pete Kaiteris	Yakovlev YAK -3	

LOW WING TRAINER SCALE MASS LAUNCH		
	4 Rounds	
Contestant	Plane	Place
Jim DeTar	Moth Minor	1
Tom Nalleen II	KI 106	2
Dave Mitchell	Miles Magister	3
Dave Franks	Fiat G-46	4
Richard Zapf	T-27	5
Pat Murray	T-34 Mentor	
Dallas Cornelius	Fiat G-46	
Jack Moses	Fiat G-46	
Walt Farrell	Miles Magister	
Jim Hemmel	Fiat G-46	
Andrew Ricci	AT-6	
Claude Powell	CA-6 Wackett	
Orville Williamson	Navion	
Chris Starleaf	T-28	
John Houck	Fairchild XNQ-1	
Jeff Runnels	T-34 Mentor	
Gene Smith	Arado 396	
Tom Arnold	Do 335	
Dick Gorman	AT-6	

WW I COMBAT		
	4 Rounds	
Contestant	Plane	Place
Stu Weckerly	Grain Kitten	1
Don DeLoach	Martinsyde F.4	2
Tom Hallman	Martinsyde Buzzard	3
Rich Miller	Fokker D-VII	4
Jim DeTar	Fokker D-VII	5
Walt Farrell	Albaross	
Dave Mitchell	Bristol Scout	
Stew Meyers	Bristol Scout	
Chris Boehm	Fokker D-VII	
Richard Zapf	Fokker D-VII	
Ronny Gosselin	Fokker D-VII	
Peter Kaiteris	Fokker D-VII	
Bob Thompson	Hannover CL-II	
Chris Starleaf	Pomilia	
Orv Olm	SE 5	
Andrew Ricci	SE 5	
Dick Gorman	SE 5A	
Jack Kacian	SE 5A	
Bernard Dion	SE 5A	
Greg West	SE 5A	
Clive Gamble	Sopwith Camel	

FAC CONTRA-PROP SCALE MASS LAUNCH		
	3 Rounds	
Contestant	Plane	PLACE
Tom Hallman	Koolhoven FK-5501	1
John Houck	A2D Skyshark	2
Ronny Gosselin	Republic XP-69	3
Steve Price	KI-64	4
John Regalbuto	Henschel P87	5
Jack McGillivray	Koolhoven FK-5501	
Tom Arnold	XP-72	
Rich Weber	Arseval VB-10	
Bernard Dion	Narval SO-8000	

FAC SHELL SPEED DASH / GREVE RACE / THOMPSON RACE							GREVE	THOMP.	
Contestant	Plane	FLT. # 1	FLT. # 2	TOTAL	SHELL PLACE	GREVE QUAL.	RACE FINALS	THOMP. QUAL.	RACE FINALS
Chris Starleaf	Rider R-4 "Firecracker"	120	120	240	1	X	7		
Jim DeTar	Lockheed "Altair"	93	128	221	2			X	11
Don DeLoach	Marcoux Bromberg S	94	101	195	3			X	4
Tom Hallman	"Loose Special"	120	72	192	4			X	3
Richard Zapf	Rider R-1 "Suzy"	65	113	178	5	X	4		
Jack McGillivray	P-W "Mr. Smoothie"	76	96	172		X	2		
Gene Smith	Marcoux Bromberg S	83	89	172				X	8
Chris Starleaf	Cessna CR-3	84	73	157				X	1
Walt Farrell	Lockheed "Altair"	83	74	157				X	2
Andrew Ricci	Cessna CR-3	59	91	150				X	10
Orv Olm	Cessna CR-3	89	56	145				X	5
Mark Fineman	Cessna CR-3	91	49	140				X	6
Walt Farrell	P-W "Mr. Smoothie"	58	70	128		X	10		
Charlie Sauter	Rider R-4 "Firecracker"	51	77	128		X	5		
Paul Boyanowski	Lockheed "Altair"	60	66	126				X	9
Richard Zapf	Allenbough Special	46	76	122		DNQ			
Dave Mitchell	Howard "Pete"	78	40	118		X	9		
Ed Pelatowski	Folkerts SK-2	58	57	115		X	3		
Charlie Sauter	Marcoux Bromberg S	81	33	114				X	7
Mike Isermann	Rider R-5 "Jackrabbit"	53	55	108		X	8		
Al Lawton	P-W "Mr. Smoothie"	45	63	108		X	1		
Gene Smith	P-W "Mr. Smoothie"	61	46	107		X	6		
Andrew Ricci	Rider R-1 "Suzy"	42	59	101		X			
Jim Hemmel	Chester "Goon"	46	45	91		X			
Dallas Cornelius	Cauldron C-460	40	46	86		X			
Mark Fineman	Folkerts SK 1	43	41	84		X			
Kent LeMon	Haines H3	29	53	82		X			
Dick Gorman	Rider R-4 "Firecracker"	44	33	77		X			
Tom Nallen	Rider R-1 "Suzy"	40	33	73		X			
Bill Mueffelmann	Howard DGA-5 "Ike"	36	29	65		X			
Mike Zand	Seversky Sev-2	31	33	64				X	
Bruce Foaster	Cauldron C-460	25	26	51		X			
AREOL RACE WINNER!							FLYING HORDE WINNER		
Dallas Cornelius	Cauldron C-460						Mike Isserman		

FAC POWER SCALE		FLT. # 1	FLT. # 2	FLT. # 3	3 FLT AVE ***	SCALE SCORE	BONUS POINTS	TOTAL	
Tom Hallman	DH-2	120	120	120	120	61.5	20	201.5	1
Chris Starleaf	DH-84 Dragon	95	68	112	91	58.25	40	189.25	2
Dave Rees	Dornier Delphin II	120	120	120	120	57.25	10	187.25	3
Fernando Ramos	Miles Magister	108	120	120	116	55.5	10	181.5	4
John Donelson	Barracuda Prototype	120	120	120	120	54.5	5	179.5	5
Ted Allebone	Vickers Vimy	35	120	41	65	60.5	40	165.5	
Mark Fineman	Boeing L-15A	120	80	120	106	53	0	159	
Ted Allebone	Walrus	71			23	61	30	114	
Tom Hallman	Waterman Aerobile	70			23	60.5	20	103.5	
Dave Rees	Dornier Delphin I	22			7	45	15	67	
*** ONE POINT PER SEC...NO FACTORING...MAX = 120 SEC'S									

FAC RAPIER JET SCALE									
Contestant	Plane	FLT. # 1	FLT. # 2	FLT. # 3	SCALE SCORE	BONUS PT'S	BEST TIME	TOTAL	PLACE
Bernard Dion	Belfagor	35	21	28	42	40	35	117	1
Mike Stuart	Martin XB-51	28	32		39	42	32	113	2
Dan Kane	BV 215	33	36	26	43	30	36	109	3
Chris Starleaf	MIG-15	33			60	15	33	108	4
Mike Stuart	Fiat G.91	22			52	20	22	94	DNQ
Bob Brown	BV 215	33	36	34	27	30	36	93	5
Ronny Gosselin	Fouga	27	27	35	39	15	35	89	
Steve Price	MIG I-270	28	28	28	27	15	28	70	

FAC POWDER PUFF SCALE									
Contestant	Plane	FLT. # 1	FLT. # 2	FLT. # 3	3 FLT AVE FAC'D	SCALE SCORE	BONUS POINTS	TOTAL	PLACE
Marie Rees	VEGA	120	67	67	72	57.5	0	129.5	1
Juanita Reichel	Wittman Tailwind	39	50	59	49	57	0	106	2
Molly Gosselin	M-S "Cricket"	23	24	40	29	55.5	0	84.5	3
Christina Hansson	Mr. Smoothie	40	41	37	39	36	5	80	
Jane Smith	PT-19	29			9	57	10	76	

FAC FICTION FLYER SCALE									
Contestant	Plane	FLT. # 1	FLT. # 2	FLT. # 3	3 FLT AVE FAC'D	SCALE SCORE	BONUS POINTS	TOTAL	PLACE
Rich Weber	Booth Ranger	81	120	66	74.5	52	10	141.5	1
John Houck	Joy's Racer	57	86	63	64	52	10	126	2
Tom Hallman	Smilin Jack X-13	65	43	66	58	56	10	124	3
Dave Stott	Ace McCoy Trainer	32	41	41	38	60	10	108	4
Ed Pelatowski	Joy's Racer	34	34	36	34	56	10	100	5
Walt Farrell	Mystery Tailless	42	25	27	31	45	15	91	
Greg West	Scarlet Stomer	39	37	47	41	40	5	86	
Bruce Foster	Loopy	52	31	43	42	24	10	76	
Lindsay Smith	Wisecrack	22	23	31	25	33	15	73	

FAC RUBBER POWERED JET SCALE									
Contestant	Plane	FLT. # 1	FLT. # 2	FLT. # 3	SCALE SCORE	BONUS POINTS	BEST TIME FAC'D	TOTAL	PLACE
Paul Boyanowski	DeHavilland Comet	52	57		54	10	57	121	1
Don DeLoach	Fokker S.14	61			42	10	60.5	112.5	2
Richard Zapf	Supermarine Attacker	79	62	43	28	10	69.5	107.5	3
Art Collard	YAK-17	76	46	55	26	10	68	104	4
Walt Farrell	MIG	82	84	85	26	5	72.5	103.5	5
Dallas Cornelius	Lavochkin LA-15	28	54	58	38	5	58	101	
Tom Arnold	F 84-F	39	57	29	37	5	57	99	
Ed Pelatowski	MIG-9	63	47	37	32	5	61.5	98.5	
Orville Williamson	L-1011	22			30	30	22	82	



**CIA TED DOCK MEMORIAL
AMA/FAC FREE FLIGHT MEET
MUNCIE AMA SITE**

SATURDAY 10/4/2008

8:00 AM - 5:00 PM

FAC OLD TIME RUBBER ROG

FAC EMBRYO ENDURANCE

FAC GOLDEN AGE COMBINED

FAC WWI COMBAT @ 11:00 AM

FAC JIMMY ALLEN

AMA P-30 (J) * (SO)*

AMA CATAPULT GLIDER (J) * (SO)*

SUNDAY 10/5/2008

8:00 AM - 4:00 PM

FAC OLD TIME RUBBER STICK

FAC 2-BIT + ONE OLD TIME RUBBER ROG

FAC DIME SCALE

FAC NO-CAL SCALE

FAC WWII COMBAT @ 11:00 AM

FAC OLD TIME PLAN/KIT SCALE

AMA HAND LAUNCHED GLIDER (J) * (SO)*

FAC JET CATAPULT

THE FOLLOWING CAN BE FLOWN EITHER DAY. BUT MUST START AND END ON SAME DAY.

FAC RUBBER SCALE

FAC JUMBO/GIANT SCALE

FAC POWER SCALE

FAC PEANUT SCALE

ENTRY FEE: FIRST EVENT \$10.00

EACH ADDITIONAL EVENT \$2.00 MAX = \$20.00

PRIZES: 1ST CUPS OR PLAQUES---- 2ND CERTIFICATES---- 3RD CERTIFICATES
JRS - 1ST PLACE = MERCHANDISE CERTIFICATES---2ND CERTIFICATES ---3RD CERTIFICATES

ALL MODELS MUST BE PROCESSED OR JUDGED BEFORE BEING FLOWN
JUDGING AND ENTRY ON SITE 12:00 - 5:00 ON FRIDAY 10/3/2008
AS WELL AS DURING THE MEET.

ALL NON SCALE MODELS MUST HAVE PROPER SIZED AMA NUMBERS
HAND LAUNCHED/CATAPULT WILL FLY FROM A PEN
*NATIONAL CUP POINTS FOR P-30, HLG, CG

CONTEST DIRECTOR: LONNIE KINDER PO BOX 208 WINDFALL IN 46076
PHONE: 765-945-7626 LONNIELKINDER@CS.COM

They Had What It Takes

XXII—JOHN ALCOCK—FIRST ATLANTIC NON-STOPPER

By ALDEN McWILLIAMS



1—Born in Manchester, England, in 1892, young John Alcock, after completion of his regular schooling, became, at the age of 18, an apprentice in a motor works. Here he quickly proved himself to be a born mechanic. Then, in 1911, the fascinating new field of aviation beckoned him. He soon soloed, and in November of 1912 he was awarded his flying license.

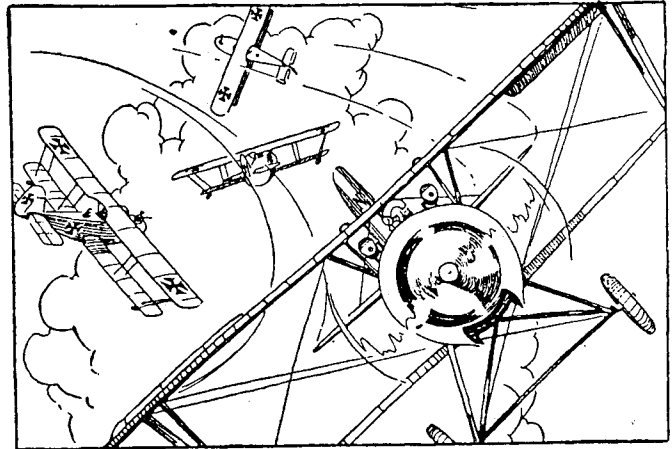

2—Using a Farman biplane for his first mount, Alcock took third in the 1914 London-Manchester air race. Then came the War, and he went to Eastchurch as an R.N.A.S. instructor. Finally, he became a flight commander on Lemnos Island, near the Dardanelles. And here he won the D.S.C. for repulsing three enemy seaplanes while flying a small single-seater.

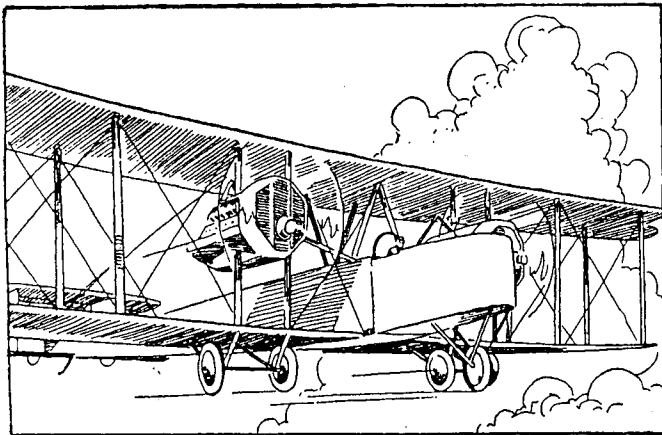

3—After leading many successful bombing raids against the Turks, the young Briton was ultimately made a prisoner, being shot down over Suvla Bay, Gallipoli. Released at the end of the War, he joined Vickers. Then he groomed a huge Vickers Vimy bomber to compete for the London Daily Mail prize of \$50,000 for the first non-stop trans-Atlantic hop.

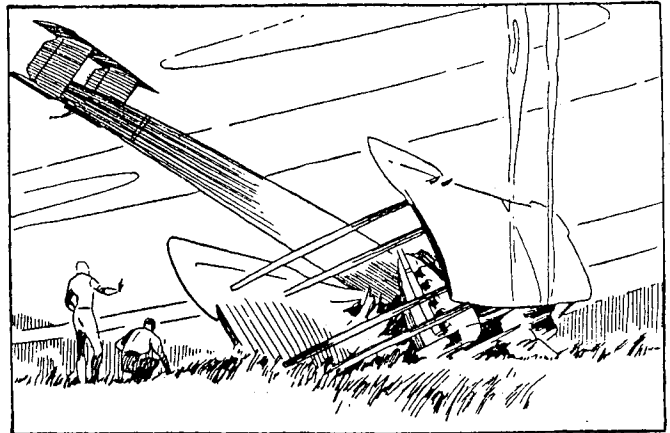

4—Accompanied by Lieut. Arthur Whitten-Brown, Captain Alcock thereupon took off from Newfoundland, June 14, 1919, and bravely headed over the ocean wastes through night-palld skies. And next morning—less than 17 hours later—he arrived at Galway, Ireland! In the heavy mist, however, the Vimy crash-landed in a peat bog which had appeared to be a smooth field.

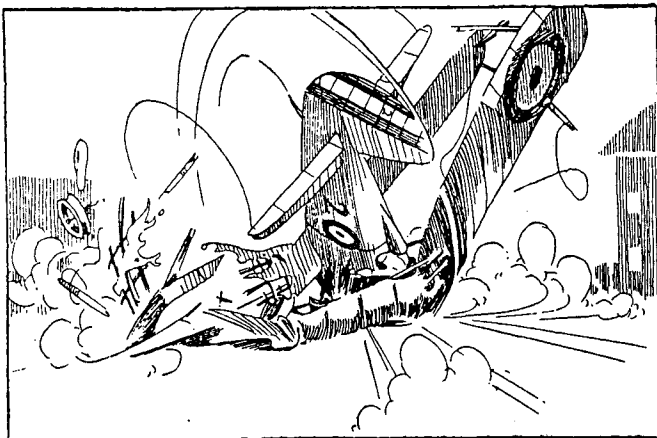

5—Immediately, the local populace cheered the flyers, neither of whom was hurt. Then the whole world resoundingly acclaimed this first non-stop conquest of the Atlantic. But shortly thereafter a sad note entered; for near Rouen, France, only six months later (December 18) Alcock again crashed in a low-visibility landing. And this time he was instantly killed.

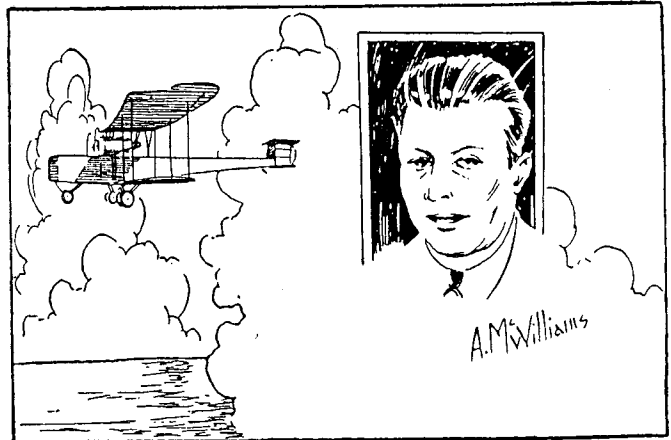

6—And so, hardly had King George knighted him when an untimely death ended the brilliant career of this 26-year-old sky hero. But Capt. John W. Alcock's 1919 Atlantic victory remains a foremost highlight of air history, unshadowed by the deeds of later ocean flyers. Meanwhile, Whitten-Brown, who was likewise knighted, is still alive in England.

FAC DIME SCALE		BONUS				TOTAL	TOTAL	GRAND	
		PT'S	FLT.	FLT.	FLT.	3	BONUS	TOTAL	
Contestant	Plane	PER FLT	# 1	# 2	# 3	FLT'S	PT'S	SCORE	PLACE
Gene Smith	Hawker Typhoon	10	53	89	120	262	30	292	1
Orv Olm	Waterman Gosling	3	80	79	118	277	9	286	2
George White	Arado AR 96	10	64	65	106	235	30	265	3
Mike Issermann	Curtiss SBC-3	15	48	44	120	212	45	257	4
Clive Gamble	Beech Staggerwing	15	57	72	72	201	45	246	5
Rich Miller	Fokker D7	15	59	56	72	187	45	232	
Steve Price	Porterfield Zephyr	0	71	120	35	226	0	226	
Dallas Cornelius	Gannet	15	94	47	39	180	45	225	
Jim Miller	Martin MO-1	5	59	83	59	201	15	216	
Dave Stott	Dewoitine D-332	10	28	110	46	184	30	214	
Chris Boehem	Bristol Brownie	10	44	44	85	173	30	203	
Mike Welshams	Pitcairn Fleetwing	15	27	88	41	156	45	201	
Jack McGillivray	Boeing Monorail	10	31	107	22	160	30	190	
Dave Mitchell	Fairchild 21	10	36	67	54	157	30	187	
Jack Moses	Beech Staggerwing	15	56	38	47	141	45	186	
Paul Boyanowski	Spitfire	10	66	37	48	151	30	181	
Mark Rzacca	Great Lakes Trainer	15	33	42	60	135	45	180	
Jeff Runnels	PT-19	10	45	45	59	149	30	179	
Dan Olah	Martin MO-1	5	72	33	54	159	15	174	
Richard Zapf	Vultee Vanguard	10	65	39	35	139	30	169	
Doug Beardsworth	Typhoon	10	46	45	45	136	30	166	
John Stott	Curtiss Falcon	15	31	49	34	114	45	159	
Greg West	Moskalaw Sigma	25	30	22	30	82	75	157	
Dave Bubolz	Beech Model D17	15	39	35	37	111	45	156	
Gene Simperts	Vega Winnie Mae	0	53	44	56	153	0	153	
Ed Pelatowski	WACO Cabin Byrd	15	30	25	40	95	45	140	
Ronnie Gosselin	Westland Dreadnaught	10	29	37	44	110	30	140	
Art Collard	Udet's Racer	10	35	36	39	110	30	140	
Ed Pelatowski	Comper swift	3	24	45	54	123	9	132	
Ray Rakow	Corbin Super Ace	3	39	43	37	119	9	128	
Walt Farrell	B.A.T. Monoplane	5	115			115	5	120	
Ed Novak	Rearwin Inst. Trainer	0	29	23	32	84	0	84	
Pau Stott	Curtiss P-36 Hawk	10	23	35		58	20	78	
Bill Mueffelmann	Arado AR 96	10	66			66	10	76	
Jim Hemmel	Martin MO-1	5	35			35	5	40	

FAC OT PLAN / KIT SCALE					3	BONUS	TOTAL		
		FLT.	FLT.	FLT.	FLT.	PT'S	BONUS		
Contestant	Plane	# 1	# 2	# 3	TOTAL	PER FLT	PT'S	TOTAL	PLACE
John Houck	Fairchild 45	108	120	120	348	10	30	378	1
Tom Hallman	WACO YKC	85	91	113	289	15	45	334	2
Orville Olm	DH Tiger Moth	63	85	120	268	15	45	313	3
Richard Zapf	HE 112	78	104	87	269	10	30	299	4
John Houck	VEGA Transport	81	101	97	279	0	0	279	DNQ
Walt Farrell	WACO	61	73	71	205	15	45	250	5
Jim DeTar	Allied Sport	67	59	85	211	10	30	241	
Mike Zand	Allied Sport	44	41	44	129	10	30	159	
John Stott	Corbin Super Ace	72	32		104	5	10	114	
Jim Miller	HE 112-B	24			24	10	10	34	

FAC RUBBER SCALE		FLT.	FLT.	FLT.	3 FLT	SCALE	BONUS		
Contestant	Plane	# 1	# 2	# 3	AVE FAC'D	SCORE	POINTS	TOTAL	PLACE
Tom Hallman	DO-X	61	43	50	51	62	51	164	1
Chris Starleaf	F-82 Twin Mustang	82	90	65	69.5	59	35	163.5	2
Mark Fineman	F-82 Twin Mustang	120	75	20	65.5	57	35	157.5	3
Andrew Ricci	Arado AR 440	66	60	48	58	59	35	152	4
Vance Gilbert	DeHavilland Flamingo	66	50	66	60	60.5	30	150.5	5
Clive Gamble	Sopwith Camel	92	120	107	79	55.5	15	149.5	
Mike Isserman	Ki 61 Tony	99	77	79	72.5	60.5	10	143	
Pat Murray	TBF Avenger	120	112	111	81	57	5	143	
Dave Mitchell	VEGA	120	120	120	82.5	60	0	142.5	HWW
Jim DeTar	Great Lakes Trainer	80	72	80	68.5	57	15	140.5	
Tom Nallen II	KI 107	101	109	45	72.5	56.5	10	139	
Tom Nallen II	Grain Kitten	120	35	63	66	57.5	15	138.5	
Vance Gilbert	Short S-26	27	32	35	31	61	46	138	
Mike Isserman	Boeing 306	46	57	59	54	59	25	138	
Dick Gorman	SE-5A	73	60	50	60.5	59.5	15	135	
Don DeLoach	Ki 61 Tony	83	87	43	65.5	58	10	133.5	
John Regalbuto	Henschel P-87	51	63	64	59	53	20	132	
Tom Nallen	Lockheed Orion	118	91		64.5	57.5	10	132	
Walt Farrell	Miles Falcon	63	67	55	60.5	58.5	10	129	
Jack Moses	P 51 A	46	46	86	59	58.5	10	127.5	
Bob Clemens	Porterfield Collegiate	120	67	33	66.5	59.5	0	126	
Bob Marchese	Fairchild 24	46	93	120	73	51.5	0	124.5	
George Mansfield	Barracuda	42	69	63	58	59	5	122	
Greg West	Y10-43A	39	41	116	62.5	53	3	118.5	
Kent LeMon	Pegna PC-1	51	49	52	50	53	15	118	
Dave Mitchell	Aero A-10	32	38	50	40	60.5	15	115.5	
John Regalbuto	Henschel P-75	39	39	35	37	55	20	112	
Ed Novak	Fairchild 22	51	59	33	47	56.5	3	106.5	
Doug Beardsworth	Kawanishi Kyofu	25	25	27	25	60.5	20	105.5	
Greg Thomas	L-19 Bird Dog	31	56	42	43	62	0	105	
Mike Stuart	FW 190D-9	34	40	29	34	60.5	10	104.5	
Dave Bobolz	PT-19	27	50	45	40	54.5	10	104.5	
Ed Pelatowski	Tailwind	44	46	48	46	56.5	0	102.5	
Mike Welshans	Piper PA-15	60	65		41	59	0	100	
Bernard Dion	BP Defiant	37	34	37	36	53.5	10	99.5	
Bernard Dion	Handley Page Hampden		22	21	14	53.5	30	97.5	
Doug Beardsworth	BF-109E	21	24	27	24	60	10	94	
Dave Rees	Fox Moth	49			16	60.5	15	91.5	
Tom Hallman	Cessna C 38	84			28	61.5	0	89.5	
Lin Reichel	Aeronca Champ	30	31	36	32	57	0	89	
Rich Weber	Bristol Scout C	32			10	61	15	86	
Mike Welshans	Fleet II	33			11	54.5	15	80.5	
Rogar Willis	Barracuda	41			13	58.5	5	76.5	

HWW = ANGUS McSCHADENFUEHER AWARD WINNER!

FAC GIANT SCALE		FLT.	FLT.	FLT.	3 FLT	SCALE	BONUS		
Contestant	Plane	# 1	# 2	# 3	AVE FAC'D	SCORE	POINTS	TOTAL	PLACE
Chris Starleaf	Dash 8	74	94	69	69.5	61	30	160.5	1
Tom Hallman	Junkers J-1	67	46	54	55	62	15	132	2
Mark Fineman	Piper Malibu Mirage	60	60	66	61	55	10	126	3
Dave Stott	Taylor E-2 Cub	59	79	74	65	59	0	124	4

FAC EMBRYO ENDURENCE								
Contestant	Plane	FLT. # 1	FLT. # 2	FLT. # 3	FLIGHT TOTALS	BONUS POINTS	TOTAL POINTS	PLACE
Frank Romsome	Crysalis	108	120	120	348	9	357	1
Don DeLoach	Embryomatic	120	106	120	346	9	355	2
Paul Stott	Gypsy	120	120	104	344	9	353	3
Lindsey Smith	Twister	116	104	81	301	9	310	4
Mark Rzasca	Puma	67	108	120	295	9	304	5
Vin Nippert	XB 2.5	87	116	88	291	9	300	
Ed Pelatowski	Cruiser	71	120	93	284	9	293	
Mike Issermann	Embryomatic	120	89	61	270	9	279	
Jim Hummel	Swallow	79	74	89	242	9	251	
Dallas Cornelius	Sharky	120	120		240	9	249	
George White	Debut	104	49	73	226	9	235	
Dan Driscoll	Future Nit	64	88	67	219	9	228	
Pete Kaiteris	Coyote	46	91	76	213	9	222	
Jim Hummel	Durham Mystery	37	110	60	207	9	216	
Bob Clemens	Lancer	59	74	72	205	9	214	
Gene Simperts	Spritzer	43	41	73	157	9	166	
John Houck	Swallow	44	62	50	156	9	165	
Mike Zand	Debut	55	51	39	145	9	154	
Stu Weckerly	Tomahawk	78	59		137	9	146	
Art Collard	Durham Myster Mode	71	53		124	9	133	
Dave Greggs	Cadet	7	60	53	120	9	129	
Ken Bagdon	Square Bird	33	32	50	115	4	119	
Jane Smith	Harlow	56	43		99	9	108	
John Stott	Mr. Malcolm	15	63		78	9	87	
George Lewis	Debut	33	8	34	75	9	84	
Chris Boehn	Yellow Cab	49			49	9	58	
Dan Kranis	Swallow	35			35	9	44	

HELP!!!

FAC JIMMIE ALLEN ROG							
Contestant	Plane	FLT. # 1	FLT. # 2	FLT. # 3	TOTAL	FLY OFF	PLACE
Don Srull	Sky Raider	120	120	120	360	120	1
Orv Olm	Skkie	120	120	120	360	106	2
Marcie Green	Skokie	120	120	101	341		3
George White	Skokie	78	120	120	318		4
Dallas Cornelius	BA Cabin	120	100	80	300		5
John Stott	Skokie	81	86	120	287		
George Mansfield	BA Cabin	83	120	81	284		
Clive Gamble	Skokie	120	77	78	275		
Linsey Smith	Skokie	120	120		240		
Ferando Ramos	Skychief	82	78	68	228		
Jim Hemmel	Sky Raider	76	75	70	221		
Jim Hyka	Skokie	63	95	44	202		
Roger Willis	BA Cabin	58	120		178		
John Houck	Blue Flash	63	58		121		
Harvey Pastel	Skokie	36	30	49	115		
Jim Coffin	JA Special	39	21	22	82		
Dominic Algieri	Skokie	48			48		
Ted Lewis	Skokie	36			36		
George Lewis	Skokie						

If you are interested in having a calendar for this year, we will need photos. They must be 9 x 12 and very clear. No dark backgrounds. If you have a person in the photo, we will need to know that persons name. Information on the plane will help.

FAC GOLDEN AGE CIVIL SCALE							
Contestant	Plane	FLT. # 1	FLT. # 2	FLT. # 3	TOTAL	FLY OFF	PLACE
Jack McGillivray	Cessna C-38	120	120	120	360	163	1
Gene Smith	Corben Super Ace	120	120	120	360	100	2
Tom Hallman	WACO YKC	107	104	120	331		3
Vic Nippert	ME 35B	120	85	120	325		4
Dave Mitchell	VEGA	82	101	120	303		5
Jim DeTar	Interstate Cadet	103	97	95	295		
Dave Stott	Monocoupe 90A	120	73	92	285		
Dallas Cornelius	Interstate Cadet	75	88	120	283		
Jim DeTar	Farman 400	73	104	101	278		
Orville Olm	Fairchild 24	90	105	80	275		
Walt Farrell	Gadfly	69	95	92	256		
Ken Bagdon	Interstate Cadet	58	89	105	252		
Mark Rzdaca	Rearwin Speedster	57	120	66	243		
Dave Rees	VEGA	81	68	89	238		
Jack Moses	Poncellet Vivette	107	66	61	234		
Dan Kranis	WACO SRE	63	110	60	233		
Jeff Runnels	Piper J-3 Cub	98	62	55	215		
John Houck	Skyfarer	66	72	75	213		
Paul Boyanowski	Porterfield Collegiate	71	70	67	208		
Richard Zapf	WACO SRE	120	51	36	207		
John Houck	RWD-5	81	67	54	202		
Andrew Ricci	Cessna C-145	55	55	79	189		
Bob Clemens	Porterfield Collegiate	67	63	58	188		
Pete Kateris	Cessna AW	54	57	72	183		
John Regalbuto	WACO SRE	64	54	59	177		
Claude Powell	Beech Staggerwing	58	56	62	176		
John Stott	Farman 400	113	48		161		
Ray Rokow	Curtiss Robin	50	58	52	160		
Stu Weckerly	Skyfarer	59	74	24	157		
Mike Zand	Taylorcraft	39	57	53	149		
Pat Murray	Stinson 125	43	49	56	148		
Ed Novak	T-Craft Grasshopper	69	33	43	145		
Bill Muffelman	Fairchild 24	65	36	43	144		
Marie Rees	VEGA	67	67		134		
Frank Rowsome	General Aristocrat	120			120		
Orville Williamson	Fairchild 24	40	49		89		
Jeff Runnels	ME-108	33	37		70		
Ralph Kuenz	Stinson SR-7	37			37		
Orville Williamson	Travel Air	24			24		
Vance Gilbert	Short Golden Hind	23			23		

FAC MODERN AGE MILITARY SCALE						
Contestant	Plane	FLT. # 1	FLT. # 2	FLT. # 3	TOTAL	PLACE
Don Srull	MIG-15	64	82	120	266	1
Tom Nallen II	Grumman Gaurdian	49	66	105	220	2
Walt Farrell	MIG-15	62	68	73	203	3
Dave Franks	Fiat G59 2A	52	76	66	194	4
Jim DeTar	Grumman Gaurdian	41	62	85	188	5
Richard Zapf	F-84-C	84	50	47	181	
John Houck	Sky Shark	35	36	47	118	
Ed Pelatowski	Grumman Gaurdian	46	34	30	110	
Tom Arnold	Mauler	50			50	

S.O.S.-----S.O.S-----S.O.S

Bill Salyards is looking for a 1938 - 1939 issue of FLYING ACES magazine containing a Kerry Keen/Griffon story by Arch Whitehouse. He has 3 FLYING ACES issues he is willing to trade, even for a zerox copy of that one story. They are: April, 1936 Back cover missing; December 1937 brittle pages/edges cut; January, 1939 Back cover missing. Anyone who is willing to trade contact Bill Salyards at P. O. Box 801, Upland, CA 91785.

FAC TWO BIT PLUS ONE OLD TIME RUBBER ROG

Contestant	Plane	FLT. # 1	FLT. # 2	FLT. # 3	TOTAL	FLY OFF	PLACE
Don DeLoach	Skokie	120	120	120	360	120	1
Marcy Green	Skokie	120	120	120	360	75	2
Paul Stott	Stahl Gypsy	120	120	100	340		3
Vic Nippert	King Harry	120	120	97	337		4
Mark Rzacca	Flying Aces Moth	116	97	113	326		5
Jack McGillivray	May Bug	120	120	86	326		
Roger Willis	BA Cabin	112	72	120	304		
Jim Hemmel	Flying Aces Moth	91	120	85	296		
George Mansfield	Flying Aces Moth	77	98	120	295		
Stu Weckerly	Erie Times	100	106	88	294		
Dallas Cornelius	Flying Aces Moth	120	72	77	269		
George White	Skokie	60	93	102	255		
Bob Clemens	Scientific Ranger	113	63	68	244		
Ken McConnell	Wren	76	84	79	239		
Ray Rokaw	Bantam	56	82	81	219		
Jim DeTar	King Harry	95	23	74	192		
Ed Pelatowski	Parlor Fly	36	50	80	166		
Jim Coffin	Flying Aces Moth	51	51	37	139		
Chris Buck	Flying Aces Moth	24	72		96		
Orv Olm	Miss Canada Jr.	95			95		
Dan driscoll	Jr. Commercial	57			57		

FAC NO-CAL PROFILE SCALE		FLT. # 1	FLT. # 2	FLT. # 3	TOTAL	PLACE
Contestant	Plane					
John Stott	Extra 400	142	133	121	396	1
Mark Fineman	Extra 400	85	107	92	284	2
Mark Rzacca	Mr. Smoothie	245			245	3
Mike Welshans	F4F Wildcat	66	90	88	244	4
Bruce Foster	Saunders ROO	72	111	53	236	5
Dennis Ruhland	Hawker Tempest	68	68	83	219	
Dallas Cornelius	Mr. Smoothie	54	59	98	211	
Ed Pelatowski	Grumman A-6	58	56	71	185	
Ed Pelatowski	Extra 400	74	58		132	
Dan Olah	Piper Vagabond	36	40	53	129	
Ara Dedekian	Grumman Avanger	29	46	30	105	
George Lewis	Gosseling	37	36	30	103	
Mark Houck	Cessna Cardinal	48	49		97	
Jerome Markson	Extra400	77			77	
Mike Welshans	Piper PA 15	55			55	
Al Mkitarian	L-19 Bird Dog	20			20	

FAC OLD TIME GAS REPLICA		TT 75	TT 120	TT 90	TOTAL DEVIATION	PLACE
Contestant	Plane					
Vic Nippert	Aerobo	-6	12	0	18	1
Bob Brown	Strato Streak	0	-18	1	19	2
Stew Meyers	Rambler	10	-12	-3	25	3
Ted Allebone	Interceptor	22	7	-4	33	4
Jerry Crowmer	Viking	7	-14	20	41	5
Mark Rzacca	New Ruler	7	32	3	42	
Bob Clemens	Zipper	7	30	8	45	
Mark Rzacca	Zipper	-6	-95	1	102	
Al Timko	Trenton Terror	0	-6			
Mark Fineman	Miss Tiny	13	63			
Mike Zand	Buzzard Bombshell	-45	-80			
Mike Zand	Mini Ruler	-33				

FAC OLD TIME RUBBER ROG						
Contestant	Plane	FLT. # 1	FLT. # 2	FLT. # 3	TOTAL	PLACE
Dan Driscoll	Wren	120	120	115	355	1
John Stott	Hornet Sr.	118	76	120	314	2
Dallas Cornelius	Ajax	65	120	110	295	3
Al Timko	Wren	77	104	103	284	4
Mike Zand	Victory	59	118	60	237	5
Tom Canfield	Jabberwock	120	41	73	234	
Vic Nippert	Miss Canada	99	120		219	
John Donelson	Miss Canada	120	80		200	
Bob Marchese	Commander	37	76	60	173	
Al Mkitarian	Megow Topper	58	54	52	164	
Chris Boehem	Pacific Ace	53	62	40	155	
Bob Lachman	Black Bullet	48	40	50	138	
Harvy Pastel	Utility Special	45	39	45	129	
Rogar Willis	FA Moth	120			120	
George White	Hi-Climber	83			83	
Ted Teach	Miss Canada	48			48	
Dan Kranis	Kestrel	42			42	

FAC GOLDEN AGE MILITARY SCALE						
Contestant	Plane	FLT. # 1	FLT. # 2	FLT. # 3	TOTAL	PLACE
Tom Hallman	Mureaux Fighter	120	95	120	335	1
Richard Zapf	Stosser	56	81	79	216	2
Mike Welshans	Martin MO-1	51	62	92	205	3
Dave Rees	Vultee V-1	54	63	45	162	4
John Houck	AVIA BH-3	50	40	60	150	5
Jack Moses	Martin MO-1	52	60	37	149	
Walt Farrell	Vultee V 11-A	45	55	42	142	
Ed Pelatowski	Spartan Fighter	30	45	51	126	
Bruce Foster	Gregor	29	27	23	79	

FAC MODERN AGE CIVIL SCALE						
Contestant	Plane	FLT. # 1	FLT. # 2	FLT. # 3	TOTAL	PLACE
Walt Farrell	Piper Clipper	102	81	120	303	1
Gene Smith	Piper Colt	96	120	63	279	2
Tom Hallman	Piper Tri-Pacer	85	85	101	271	3
Jim DeTar	Piper Tri-Pacer	105	40	120	265	4
Dave Mitchell	Navion	116	64	82	262	5
Jeff Runnels	Cessna 180	65	120	36	221	
Mark Fineman	Extra EA-500	77	60	59	196	
Stu Weckerly	Found 100	60	80	35	175	
Vic Nippert	Centennial	75	60		135	
Dave Rees	Super Cruiser	59	59		118	
Vic Nippert	Turbo Porter	48	46	21	115	
Douglas Griggs	Cessna 180	30			30	

FAC JUMBO SCALE									
Contestant	Plane	FLT. # 1	FLT. # 2	FLT. # 3	3 FLT AVE FAC'D	SCALE SCORE	BONUS POINTS	TOTAL	PLACE
Chris Starleaf	Savoia-Marchetti S-79	84	84	60	68	59.5	30	157.5	1
Vance Gilbert	Lancaster Dart	96	77	81	72	60	17	149	2
Tom Hallman	Gadfly	58	120	80	73	60	10	143	3
Dave Rees	CANT	53	46	50	49	60.5	30	139.5	4
Jack Moses	IS-4	69	120	120	78.25	54.5	5	137.75	5
Mike Stuart	A.W. Argosy	34	40	26	33	58	40	131	
Mark Fineman	SM 92	67	27	26	40	57.5	30	127.5	
Ed Pelatowski	Folkerts SK-3	56	48	83	61	59.5	5	125.5	
Luc Martin	TA 152	109			36	51.5	10	97.5	
Rich Weber	Vicker FD-5	22			7	61.5	20	88.5	

FRENCH DESIGN		
TARGET TIME = 30 SEC.		
Contestant	Plane	PLACE
Tom Nallen	Potez 34	1
Ross Mayo	Farman Moustique	2
Claude Powell	Bede Jodel	3
Don Srull	Mureaux	4
Mike Zand	Farman Moustique	5
Rich Weber	Arsenal VB-10	
Al Mkitarian	Bede Jodel	
Bruce Foster	Caudron 360	
Ed Novak	Caudron C-460	
Richard Zapf	Caudron C-460	
Dallas Cornelius	Caudron C-460	
Stew Meyers	Caudron G-3	
Greg West	DeBruyere C-1	
Dave Stott	Dewoitine D-332	
John Houck	Durine Turbulant	
Ronny Gosselin	Fouga	
Jeff Runnels	Jodel D9	
Walt Farrell	Maboussin	
Mike Isserman	Mauboussin	
Luc Martin	Rene Leduc RL-16	

GOODYEAR / FORMULA RACE		
3 Rounds		
Contestant	Plane	Place
Gene Smith	Ricochet	1
Paul Boyanowski	Whittman Buster	2
Jack Kacian	Whittman V	3
Chris Statleaf	Pogo	4
Dick Gorman	Sonerai 1 FV	5
Richard Zapf	WLH-1	
Ste Weckerly	Wittman Buster	
Dan Kane	Ole Tiger	
Ed Pelatowski	Ole Tiger	

BLUR RACE		
Contestant	Plane	Place
Pete Kaiteris	Jackrabbit	1
Chris Starleaf	YAK-11 Checkmate	2
Andrew Ricci	Keith Rider R-6	3
John Regalbuto	Macchi CS-15	4
Ed Pelatowski	Folkerts SK-2	5
Jack Kacian	Meteor	

FAIRCHILD 24	
3 Rounds	
Contestant	Place
Orv Olm	1
Richard Zapf	2
Chris Starleaf	3
Vic Nippert	4
Bob Marchaese	5
Bill Mueffelman	
Doug Griggs	
Orville Williamson	
Bill Lachman	
Dave Franks	
Tom Canfield	
Dallas Cornelius	
Jack Moses	
George White	

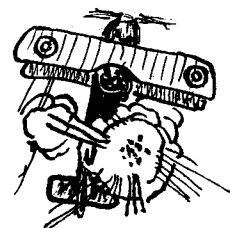

FAC OLD TIME SPARKY ROG					
Contestant	FLT.	FLT.	FLT.	TOTAL	PLACE
	# 1	# 2	# 3		
Don DeLoach	120	120	120	360	1
Ted Allebone	96	120	75	291	2
Jack Moses	120	98		218	3
Bob Hammet	84	109		193	4
Dan Olah	64	63	64	191	5
Tom Canfield	83	82		165	
Mike Zand	75	40	44	159	
Ted Lewis	73	42	38	153	
Dan Driscoll	89			89	
Mike Welshans	56			56	

AT-6 ENDURO	
3 Rounds	
Contestant	Place
Andrew Ricci	1
Ed Pelatowski	2
Richard Zapf	3
Tom Nallen II	4
Gene Smith	5
Jeff Runnels	
David Franks	
Jack McGillivray	
Dick Gorman	
Rich Weber	
John Houck	

FAC PIONEER SCALE					3 FLT				
		FLT.	FLT.	FLT.	AVE	SCALE	BONUS		
Contestant	Plane	# 1	# 2	# 3	FAC'D	SCORE	POINTS	TOTAL	PLACE
Tom Hallman	Bleriot 25	90	89	98	75.5	61	15	151.5	1
Jim Miller	Bleriot VII	61	62	78	63.5	54	10	127.5	2
John Houck	Eastbourne Monoplan	46	57	42	48	51	5	104	3
Ed Novak	Eastbourne Monoplan	29	37	40	35	58	5	98	4

FAC OLD TIME STICK								
		FLT.	FLT.	FLT.		FLY	FLY	
Contestant	Plane	# 1	# 2	# 3	TOTAL	OFF	OFF	PLACE
Vic Nippert	Thermalier	120	120	120	360	180	180	1
Ted Teach	Gollywock	120	120	120	360	180	137	2
Al Timko	Gollywock	120	120	120	360	180	92	3
Dan Driscoll	Miss Production	120	120	120	360	149		4
Mike Zand	Gollywock	93	120	47	260			5
Dan Driscoll	Thermal Bagger	37	59	88	184			
Fred Wunsche	Gollywock	120	120	42	282			
Vic Nippert	Stratometer	103			103			
Mark Rzacca	Gollywock	87	109	110	306			
Tom Canfield	Gollywock	60	120	62	242			
Dallas Cornelius	Gollywock	120	120	112	352			
Ken McConnell	Gollywock	89	89	95	273			
Bob Marchese	Thermal Bagger	120	89		209			
George Lewis	Korda	27			27			



Captain Rutherford Lincoln Washington 3rd, DFC, PAL, BMF, was our honored quest speaker. His age is unknown, but just a shy younger than Dave Stott as the Captain was too young to be a waiter at the last year like Dave.

Not able to secure flying lessons here in the states like it was so long ago, Rutherford stowed away on a tanker ship to end up in Poland with the secret Polish Air League. Even there to get by with such dark skin tones, he had to convince officers he was from Serbia-Montenegro. His flying skills eventually earned him the nick name of "The Winged Dark Man From Serbia-Montenegro." That got shorten to "Montenegro" and then shortened even further to just "Hey Negro!"

The Captain related how he never got credit for several things he originated. Like transporting an expatriated Pole who was caught spying for the Germans. The Capt. secured him to the lower rigging of his biplane with hand cuffs, wire, etc. The transport system came to be known as the "Pole-lock," but he didn't get credit for that. Nor did he get his just due for creating the "NAACP." That is "Negroes Are Actually Colored Pollacks."

Just a few high lights from the entertainment of Captain Rutherford Lincoln Washington 3rd, a.k.a. Vance Gilbert.

* * **Improving Stability** * *

Mumbo Jumbo #136 from the Glue Guru

Model stability woes tend to be of two basic types: fore and aft (longitudinal) or spiral (lateral). Each type can vary in strength from the annoying to the fatal; each requires correction of a different sort.

Consider fore and aft. One likely form of instability occurs at the beginning of flight. The model heads upwards with too much zest, stalls at the peak of climb, and then drops so as to lose most of its altitude. What is to be done?

There are at least four different causes and all four may be present and working together. None can be rejected out of hand. These are:

1. Incorrect thrust line angle.
2. Incorrect center of gravity location.
3. Incorrect setting of horizontal tail angle.
4. Incorrect propeller pitch.

To proceed, go back to glide testing and make sure the model offers a decent glide. If not, fiddle with (2) and (3) until all is well. For (2) a C.G. location, try a quarter of the wing chord back from the wing's leading edge, and for (3), you might start testing with a tail incidence equal to that of the wing incidence. At this point, the glide witnessed need not be perfect, but it must be respectable before going ahead.

Next is the setting of the thrust line. It should be pointed downwards by three to ten degrees, depending on just how much thrust is developed. Only trial and error can determine the winning setting. If unwanted zoom persists, increase the amount of downward angle used. Finally there is (4) the effect of too low a prop pitch, a design setting used by some commercial plastic props. These tend to produce a burst of thrust that is both too powerful and of too short a duration to be useful. Switch to something offering a greater pitch angle – say 25 to 30 degrees at the 2/3 diameter

position.

Granted a decent glide plus enough attention to all four of the potential trouble makers above, initial instability of the zoom, stall and crash type is most unlikely.

However, another mode of longitudinal instability may then be noticed: that of oscillation in glide, with up and down swings of incidence becoming progressively larger until the model stalls and crashes.

There are at least three causes of this sort of behavior, all related to the basic problem: lack of longitudinal stability. These are:

5. Lack of sufficient horizontal tail area.
3. Incorrect setting of the horizontal tail angle. (As before)
2. Incorrect center of gravity location. (As before)

The unstable glide wasn't detected by prior, hand launched glide testing, because the flight time was too short. Some forms of glide instability develop slowly and require many seconds to become evident. If this is the case, to seek a solution, fiddle again with (2) and (3). Moving the C.G. forward should help. As for tail incidence, it should be very close to that of wing incidence.

However, the most likely need is given by (5). If your tail area is true scale or something approaching it – say less than a quarter of the wing area – the odds are that only a major increase will help. This usually means back to the building board, although sometimes the addition of fake “elevators” fashioned of sheet balsa and held on with drafting tape will help.

An Advert for Myself

For an in-depth look at the exciting world of the Red Baron, check out *Gunning for the Red Baron*, by Leon Bennett and published by Texas A & M University Press. Sold by Amazon, B & N and all the usual bookstores.

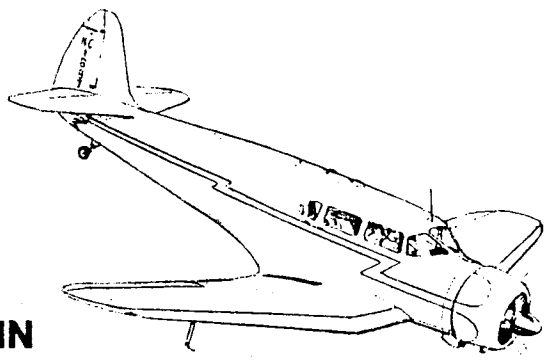
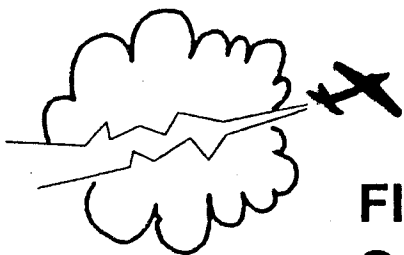

**Flying Aces Club
Outdoor Champs**
AMA Flying Site - Muncie, IN
Sept. 5th and 6th
8:30 AM to 4:00 PM
AMA Sanction # 08-0807

Fri. Sept. 5th

- FAC Scale *
- FAC Jumbo Scale *
- FAC Power Scale *
- FAC Peanut Scale
- Golden Age Scale (Civ & Mil Comb.)
- FAC Dime Scale
- Old Time Gas Replica
- Embryo
- Old Time Rubber Cabin - Must ROG ****
- World War I Combat - Bi Planes Only - ML
- Greve Race - ML
- Rearwin Speedster *****

Sat. Sept. 6th

- FAC Scale *
- FAC Jumbo Scale *
- FAC Power Scale *
- Modern Military Scale
- FAC No Cal Scale
- Low Wing Trainer
- AMA P-30 **
- Old Time Rubber Stick
- World War II Combat - ML
- Thompson Race - ML *****
- Peanut Race Planes - ML***

All Planes for Scale Judging must be turned in by 12:00 Noon Friday for both days events
OT Rubber times must be turned in by 3:00 PM each day (for fly offs)

- * FAC Scale events with * can be flown either day. Judging is on Friday only
- ** Flown to latest AMA Rules
- *** Any Era of Race Plane, must have correct colors and numbers
- **** Must ROG - Take off platform provided
- ***** No Mr. Mulligan
- ***** Golden Age Rules and construction per 2007 FAC Plan

\$25.00 Entry Fee Flies all events and includes a free T-Shirt and Fairchild 45 Plan
Plan compliments of 'Full Size Plans' (309)342-7474, www.fullsizeplans.com

All Entrants must hold a current AMA or MAAC License
Trophies awarded to Third Place

Questions, Comments, Directions; Contact Contest Director Ralph Kuenz @ 1-989-506-0273
or Fred Gregg: 1-586-884-6919 / loopy.cbfac@yahoo.com
*** Event Sponsors Welcome ***

Registration:

Make checks out to : Cloudbusters MAC

Mail to: Fred Gregg 13701 Provincial Dr., Sterling Heights, MI 48313-2018

Name _____ AMA# _____
Street _____ City _____
State _____ Zip _____ Shirt Size M L XL XXL

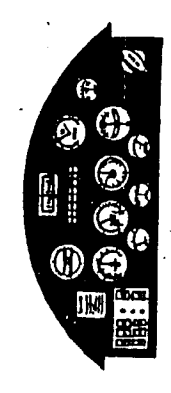
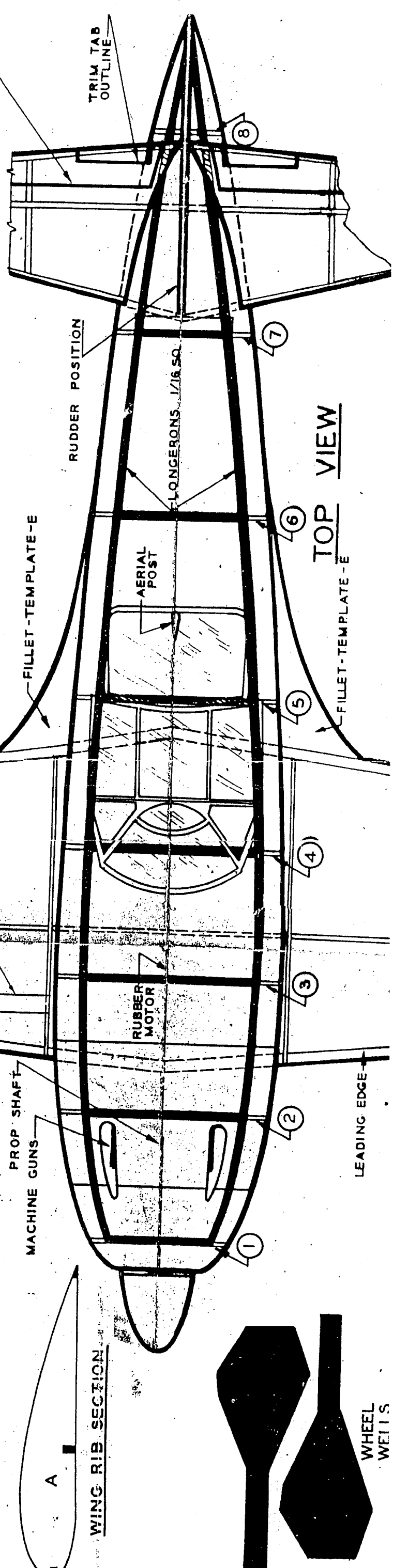
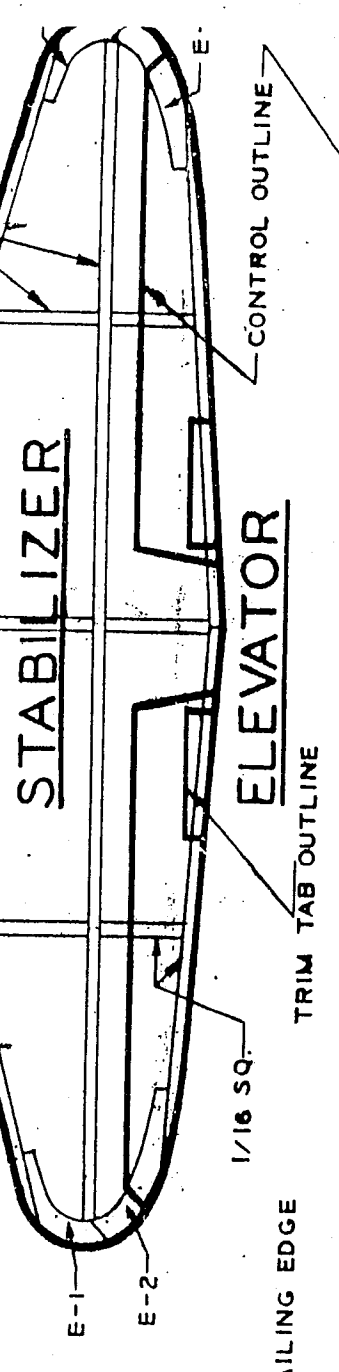
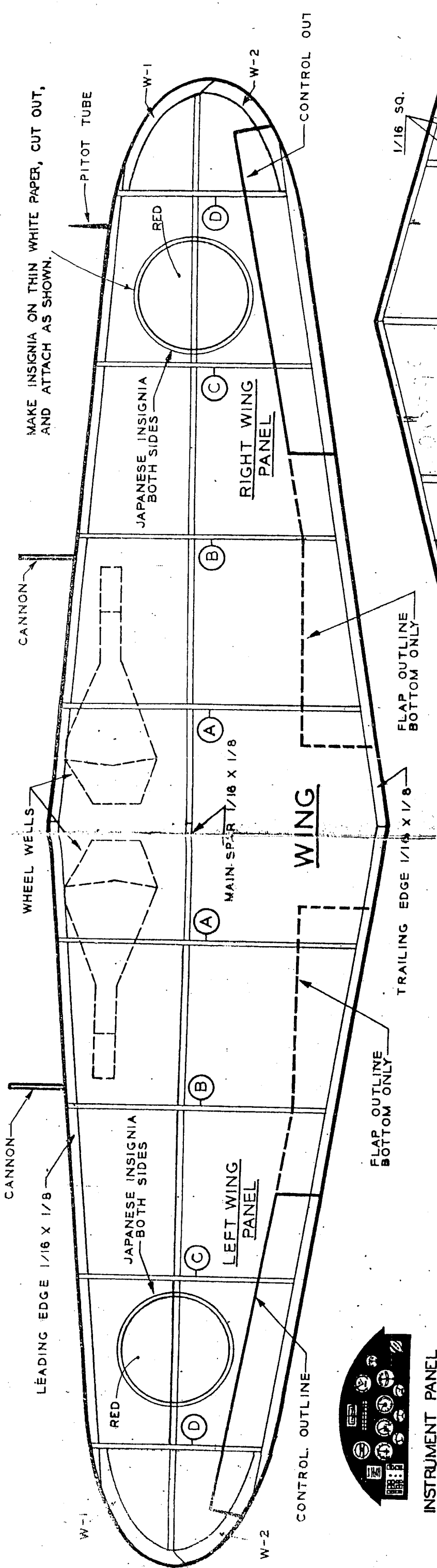

INSTRUMENT PANEL
GLUE ON 4A

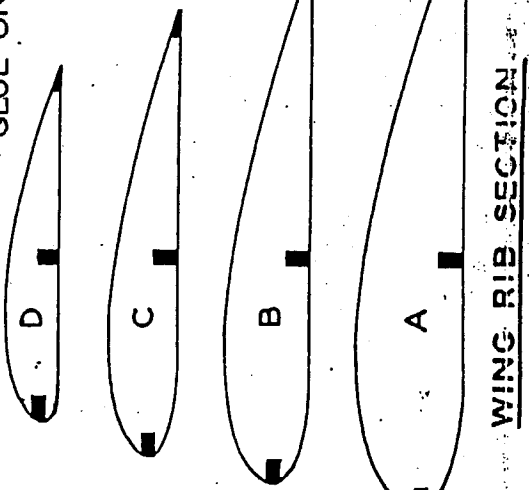

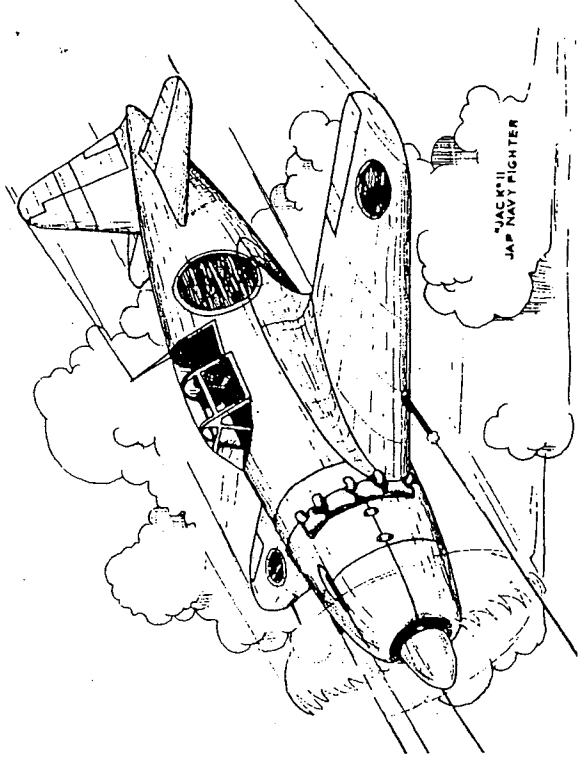

"JACK" II
JAP NAVY FIGHTER

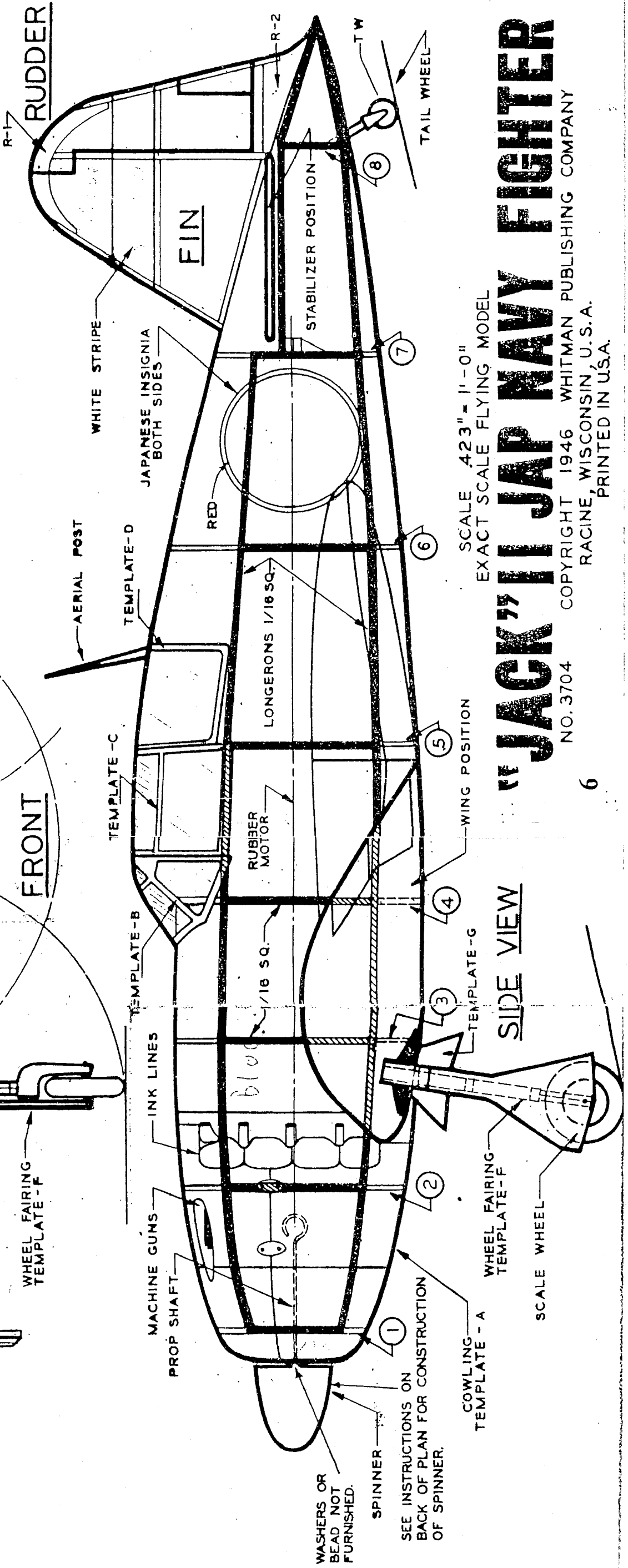
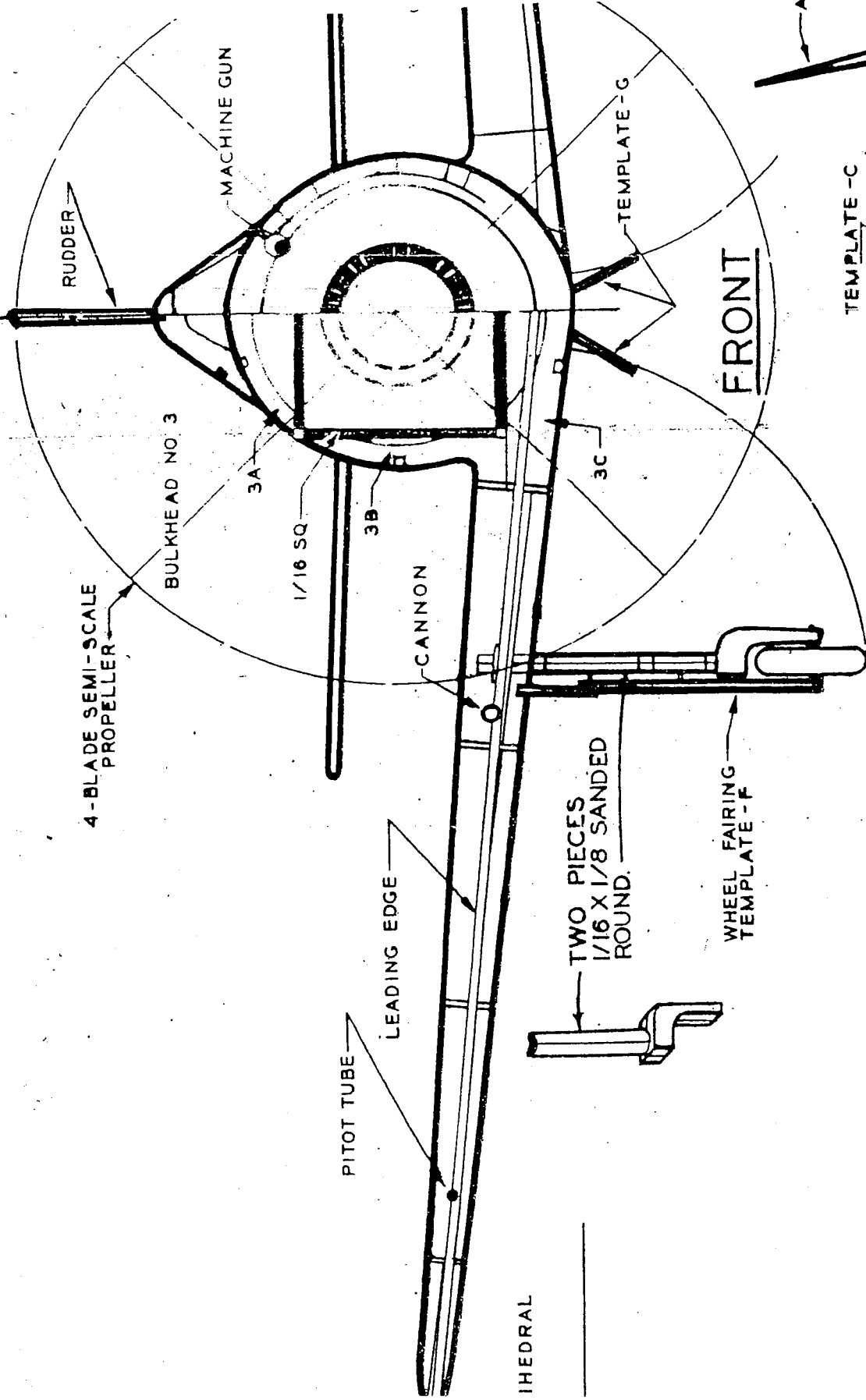

SCALE 423" = 1'-0"
EXACT SCALE FLYING MODEL

"JACK" II JAP NAVY FIGHTER

NO. 3704 COPYRIGHT 1946 WHITMAN PUBLISHING COMPANY
RACINE, WISCONSIN, U.S.A.
PRINTED IN U.S.A.

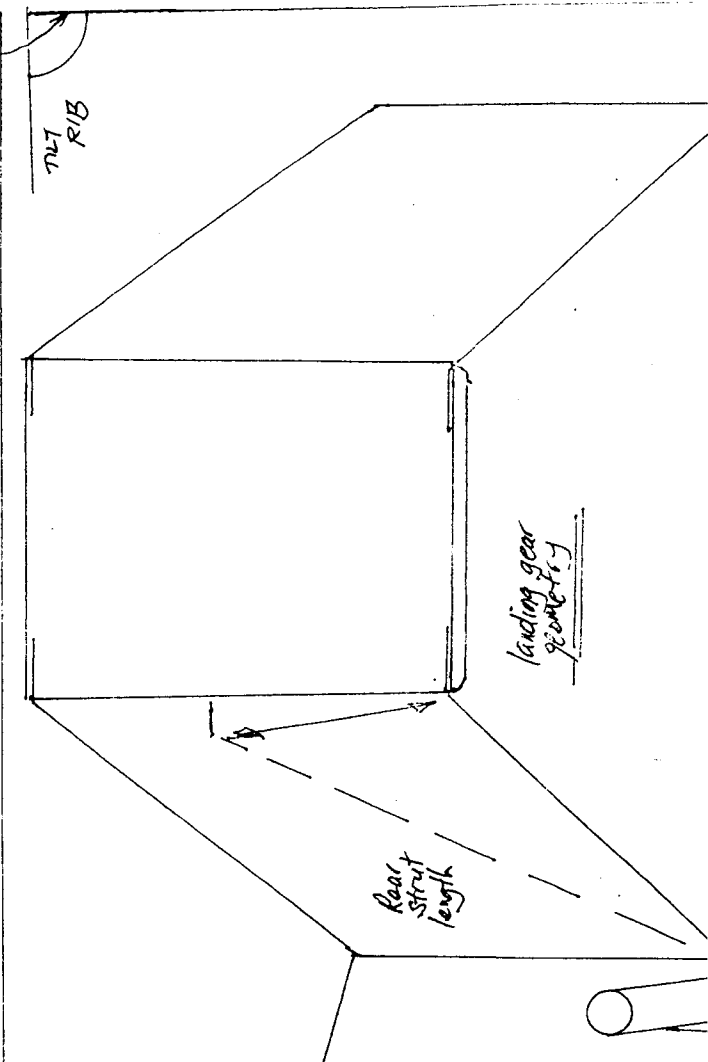
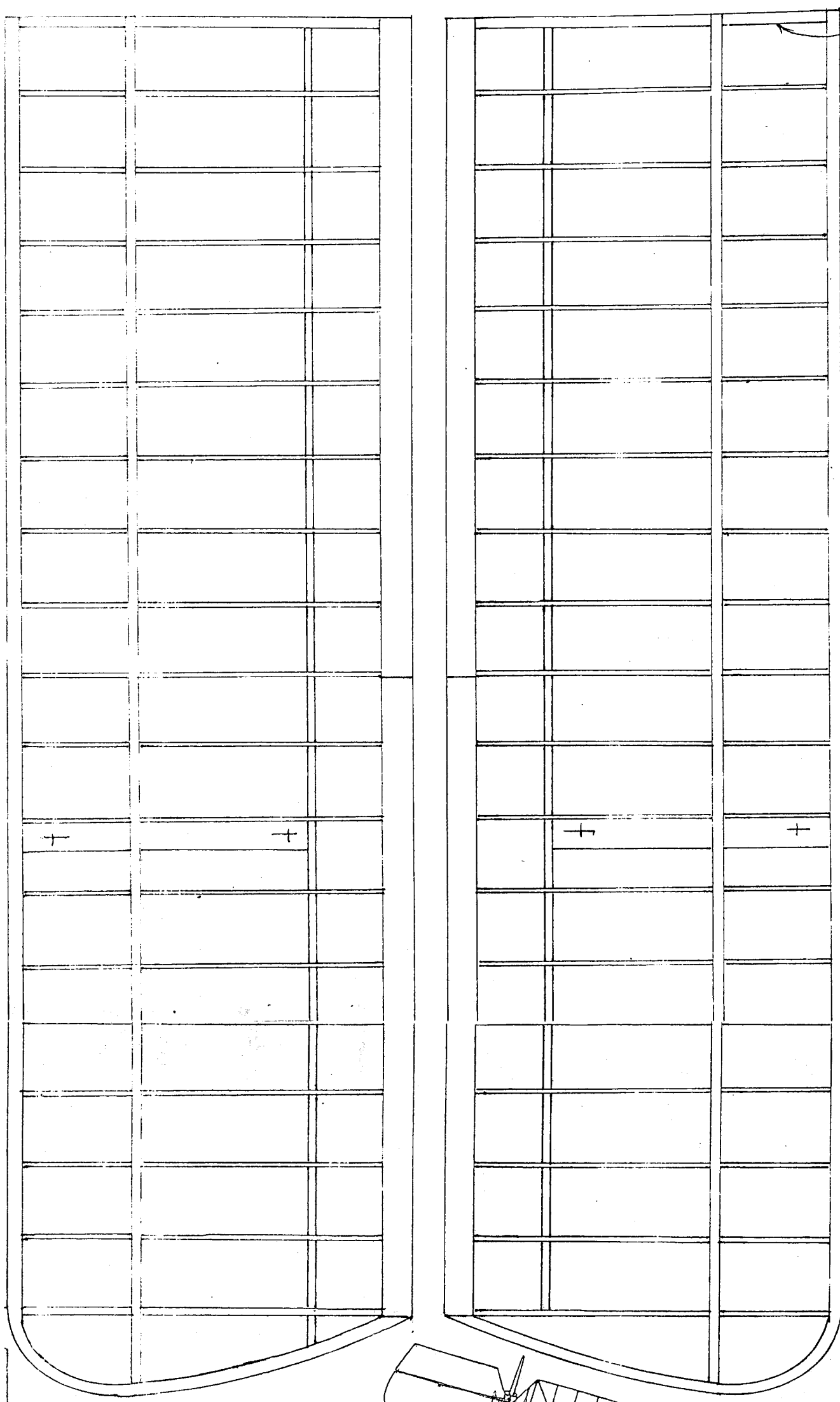

DIHEDRAL

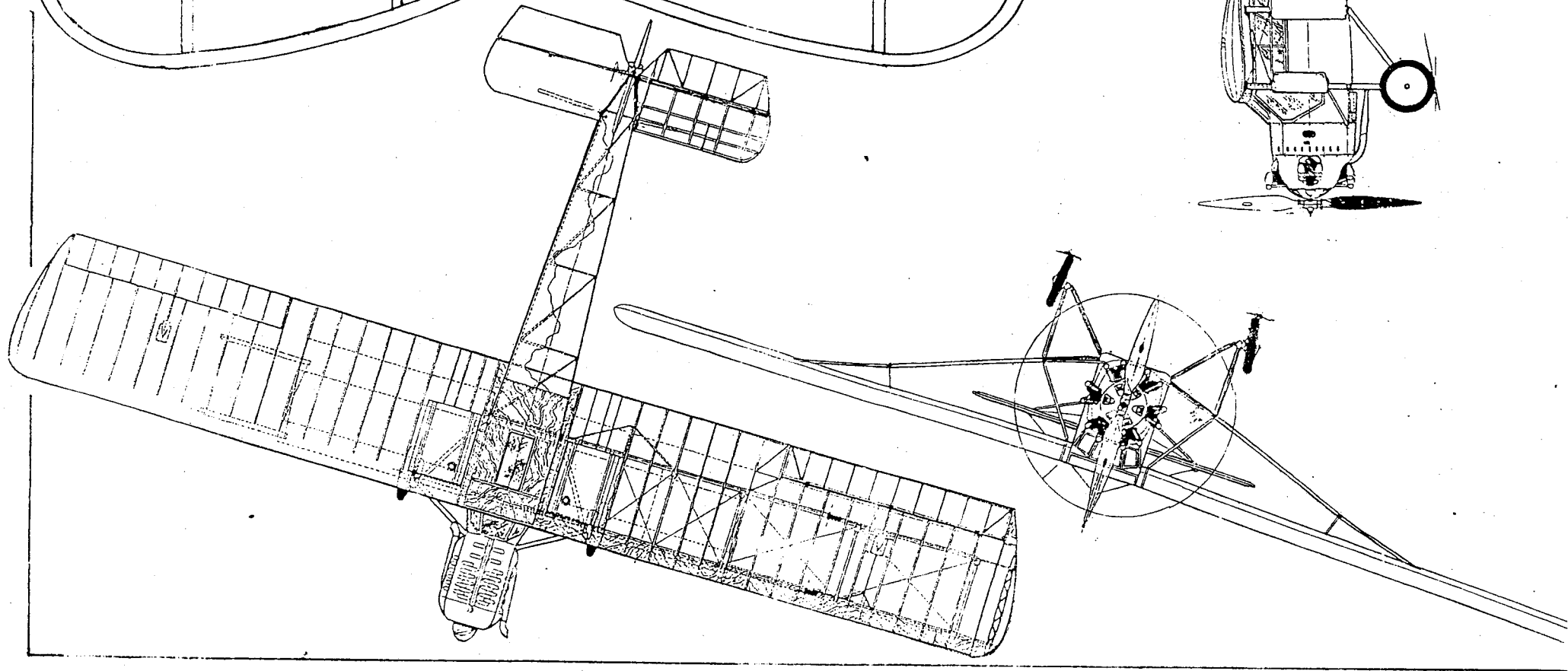

CURTISS ROBIN
SHEET 2.

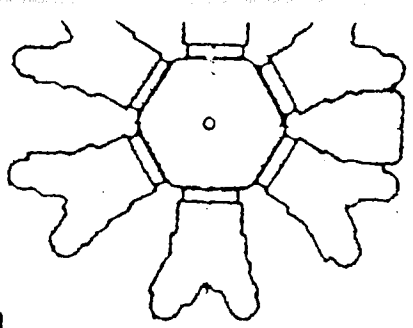
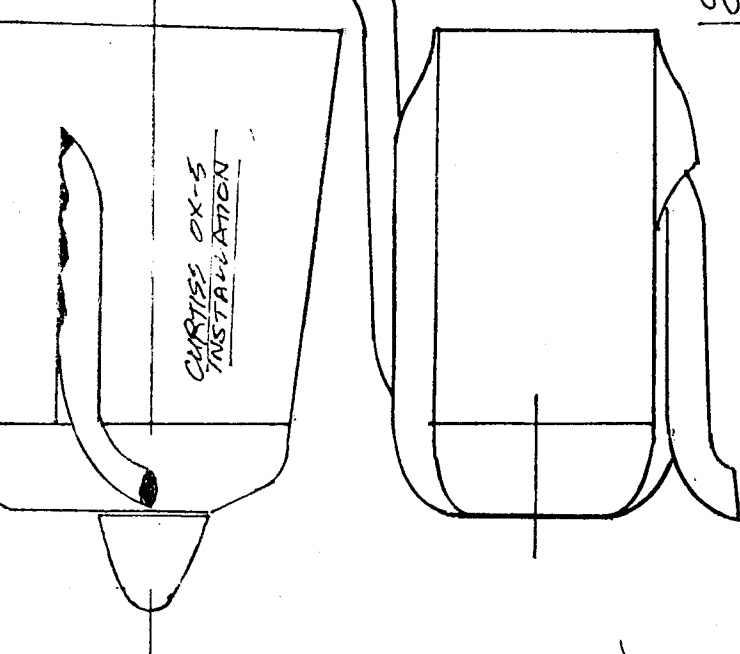
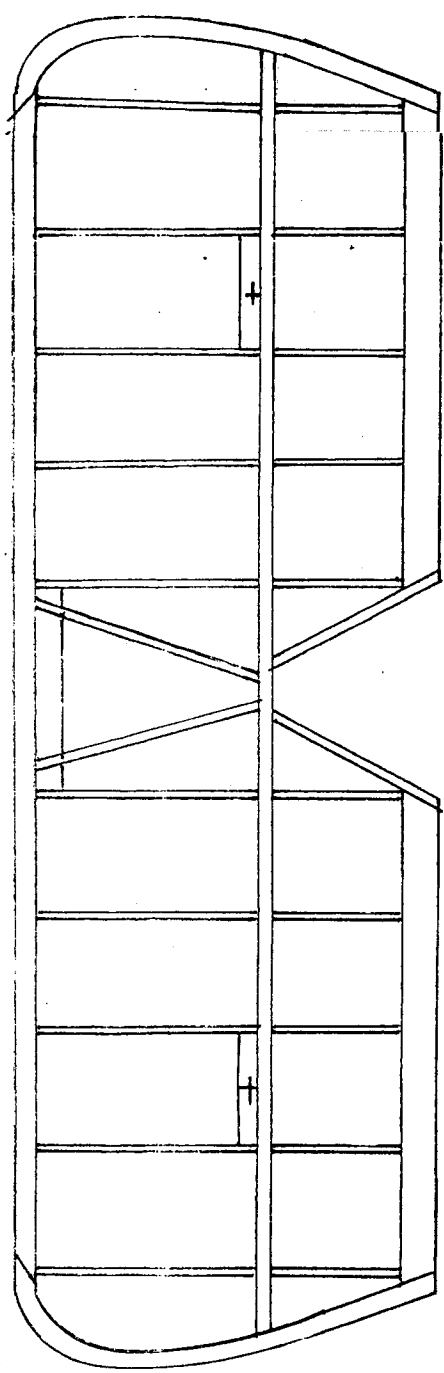

CURTIS CHALLENGER

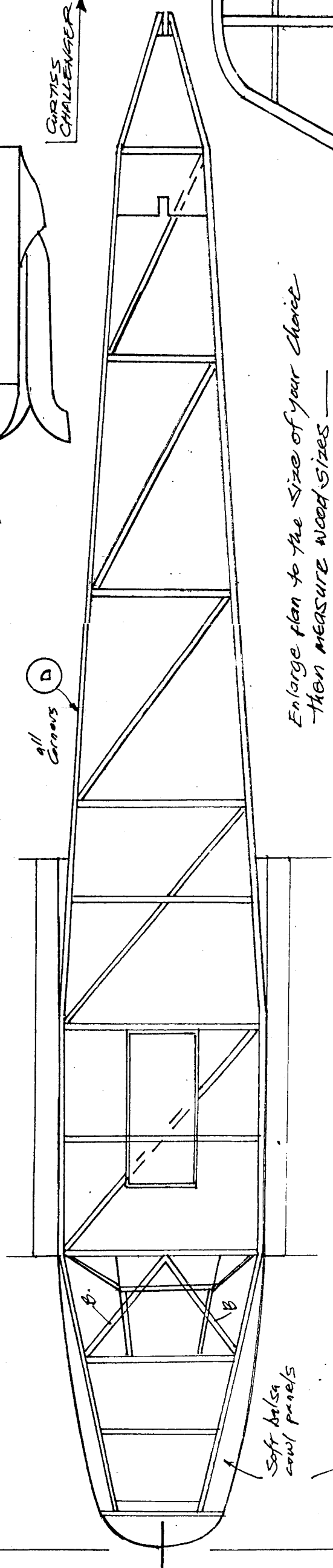

Enlarge plan to the size of your choice
then measure wood sizes

Soft balsa
cowl panels

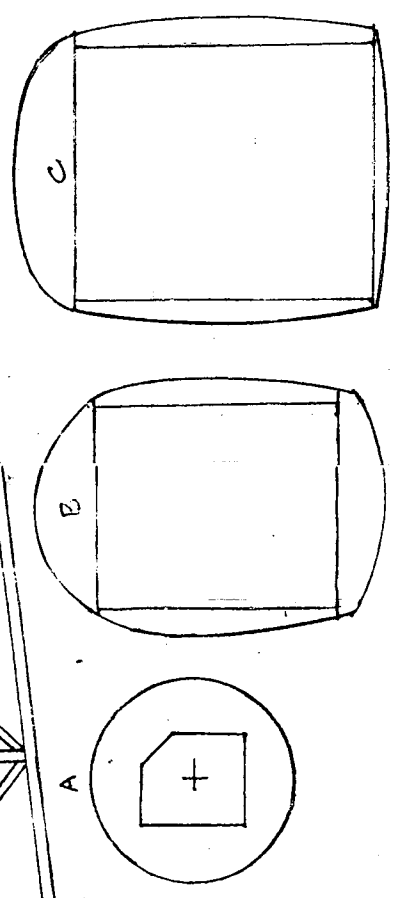
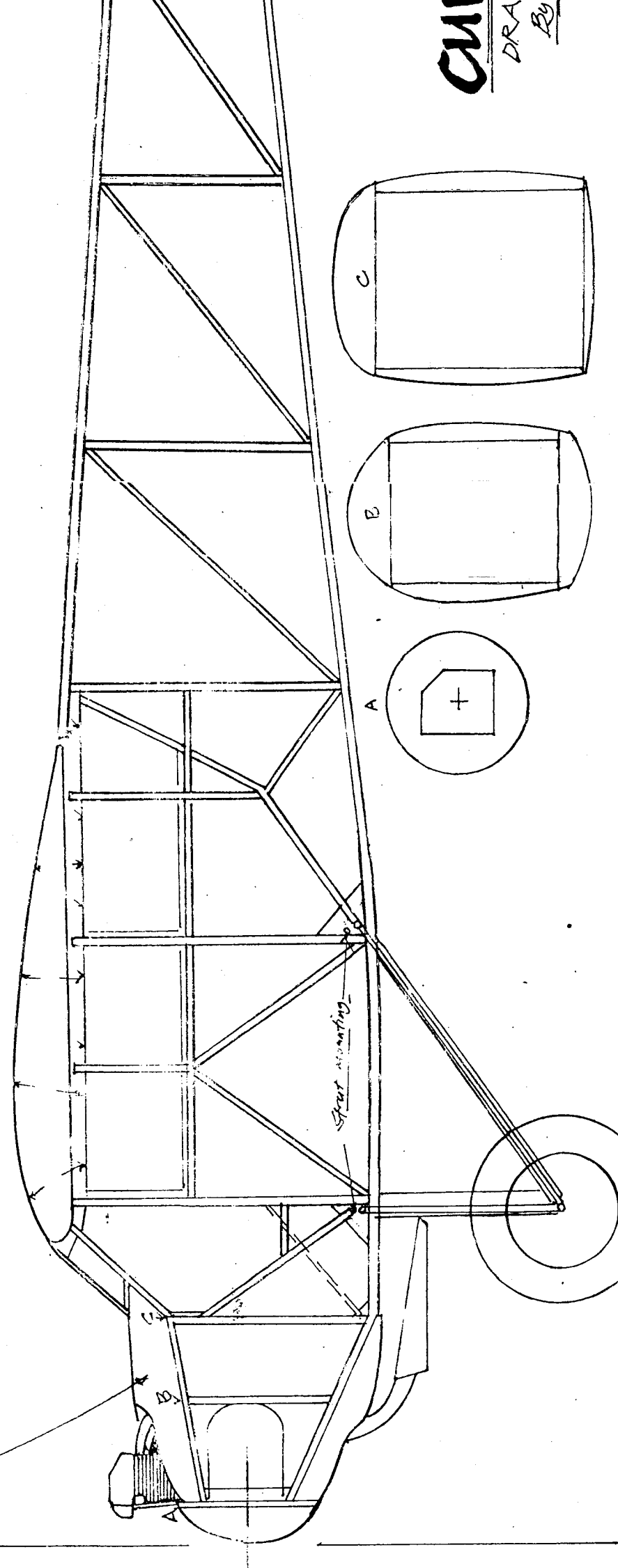
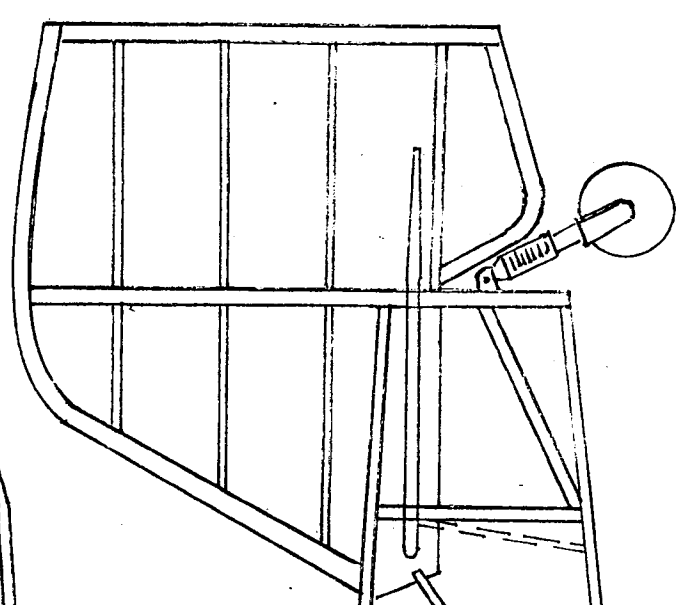

CURTIS ROBIN

DRAWN FOR FLYING AGES DOWNUNDER
By LLOYD WILLIS/2007

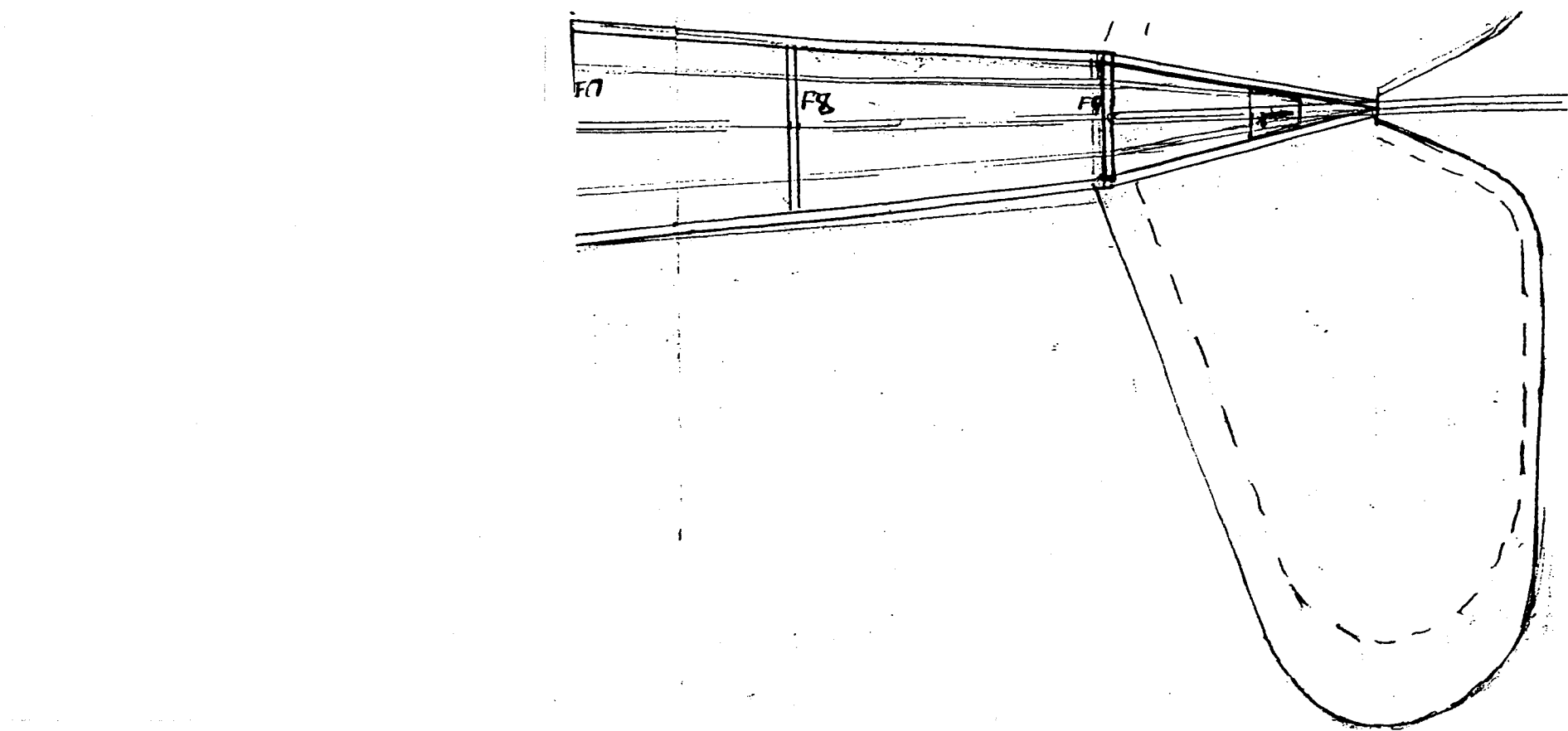
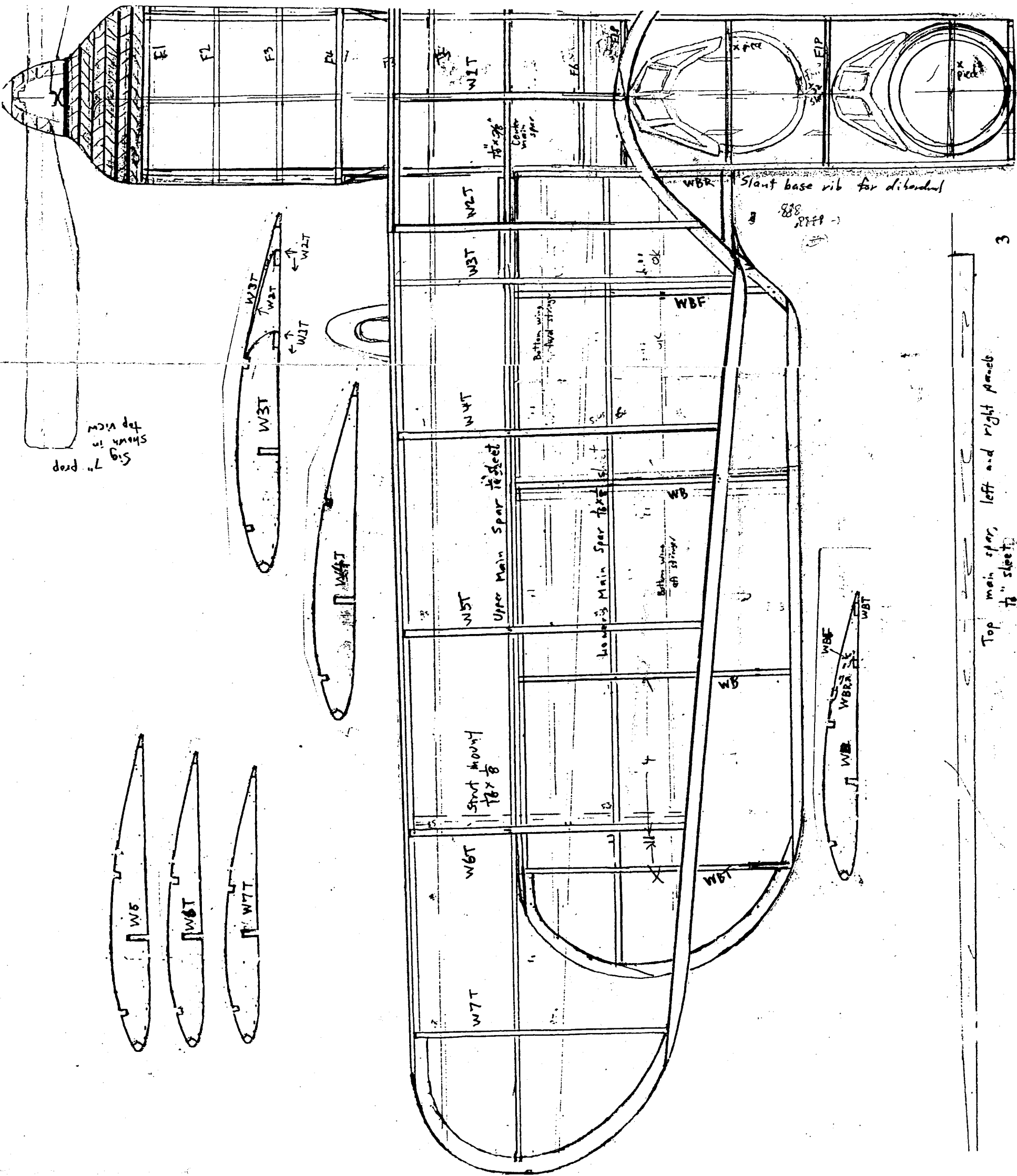

Sig 7" prop
shown in
top view

Top main spar, left and right panels
7/8" sheet

KAWASAKI Ki 3

Type 93 (1933) Light Army Bomber

1/24 scale 1/2" = 1' 21.33" span

by Nate Sturman Jan 2, 2003

