

# FLYING ACES

ISSUE # ~~81~~ JULY-AUG. 1982

## Club News

82

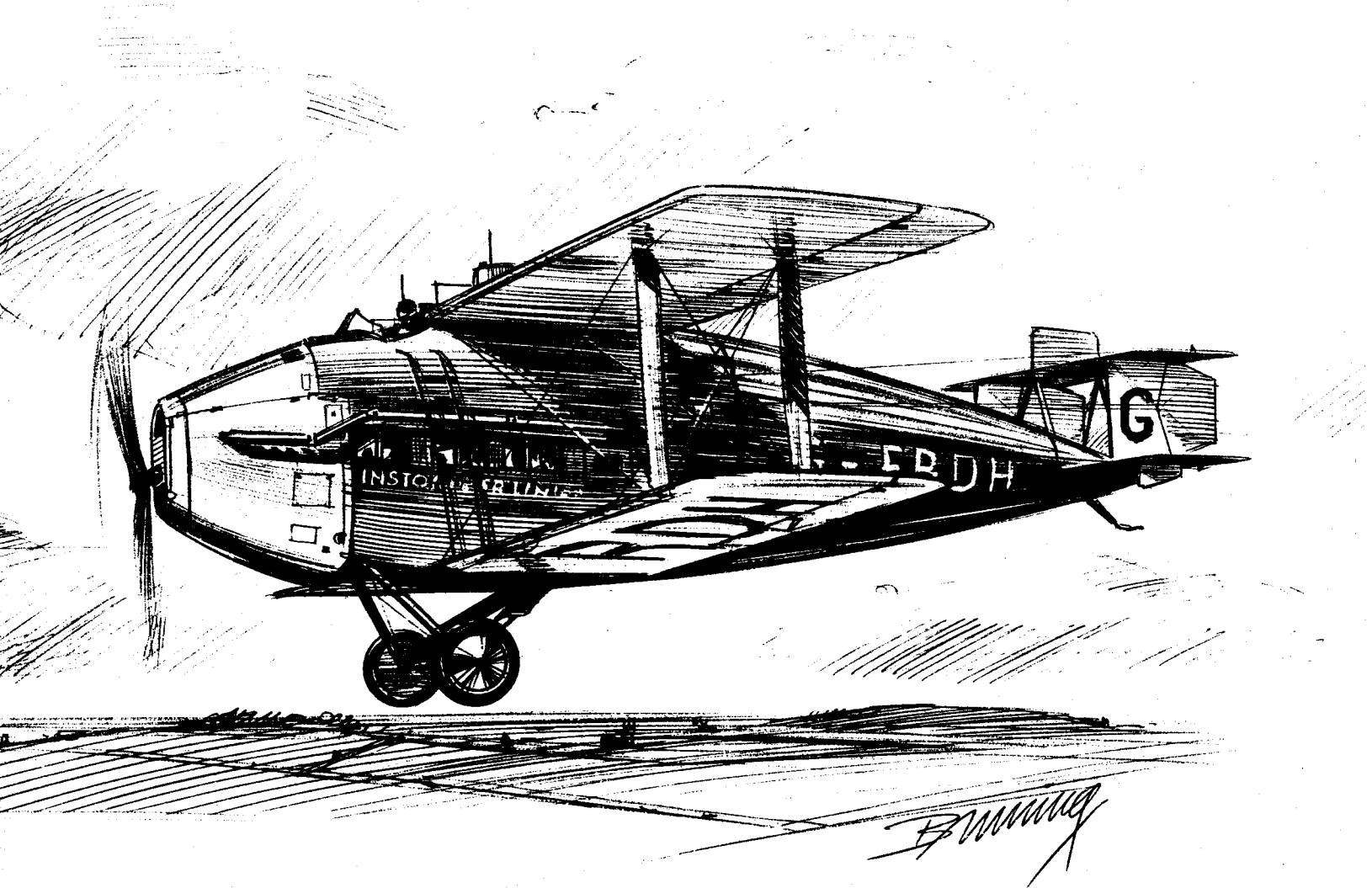

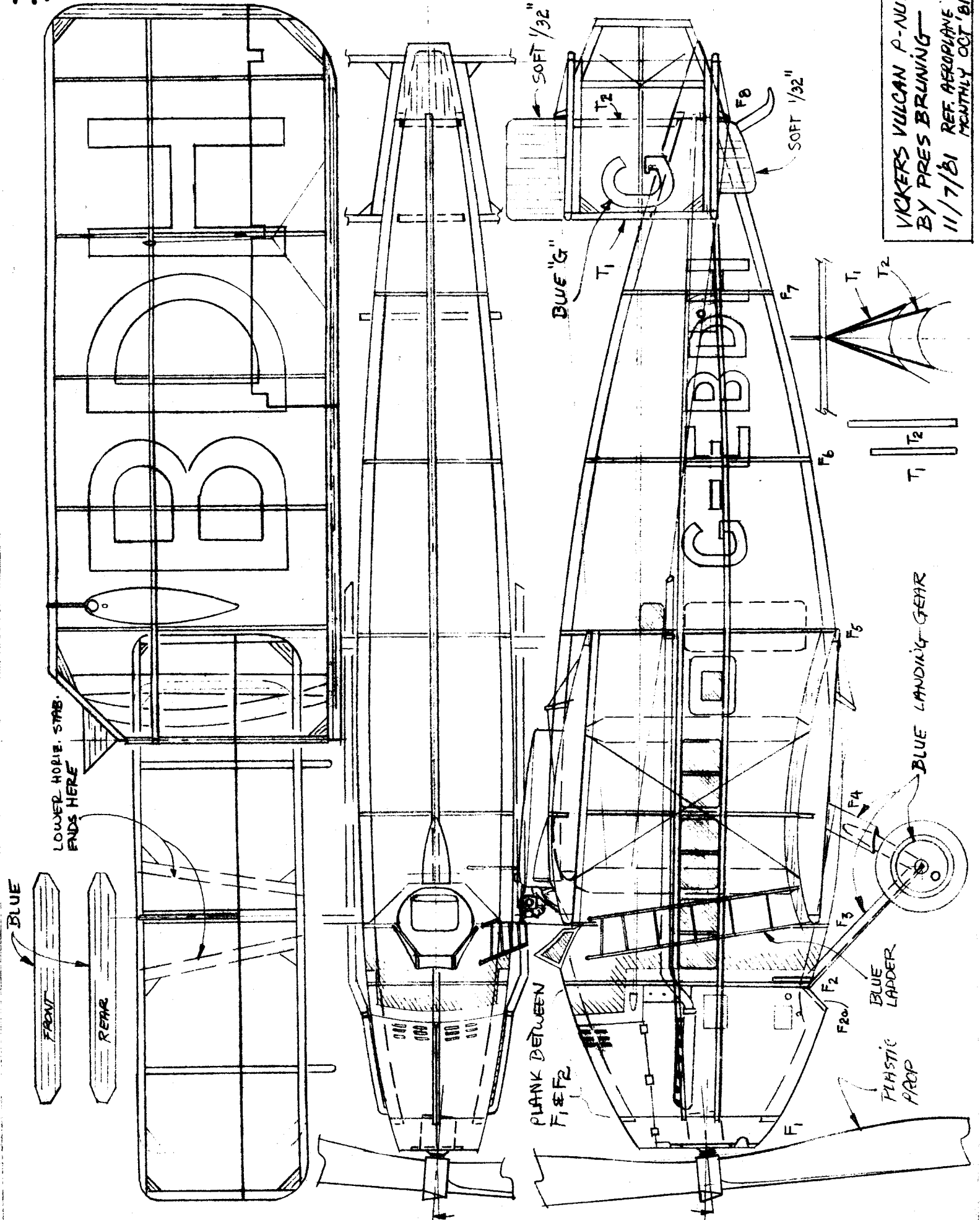

VICKERS VULCAN P-NUT  
 BY PRES BRUNING  
 11/7/51 REF. AEROPHANE  
 MONTHLY OCT '51

LOWER WING ONLY

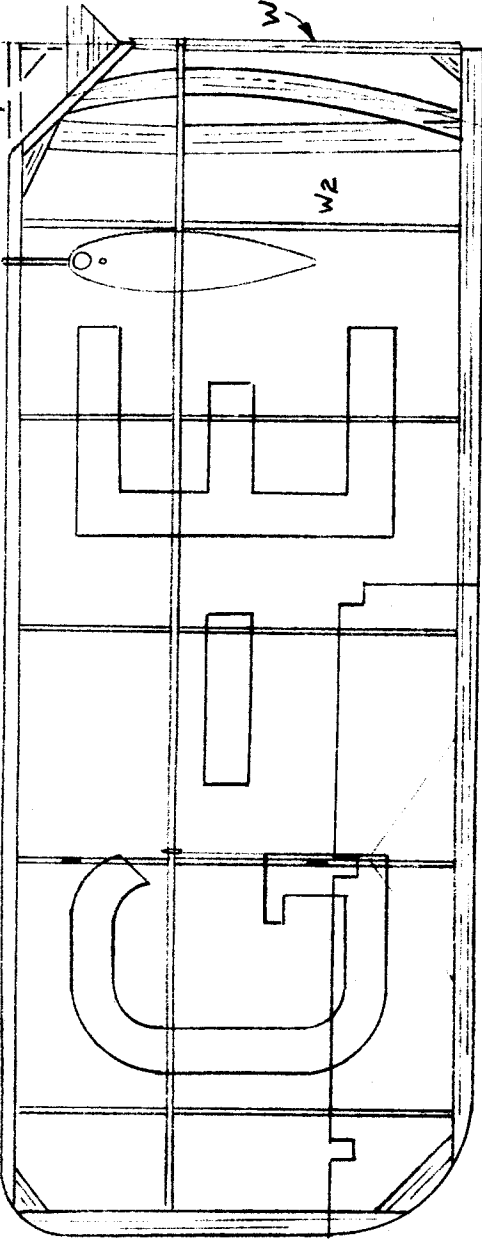
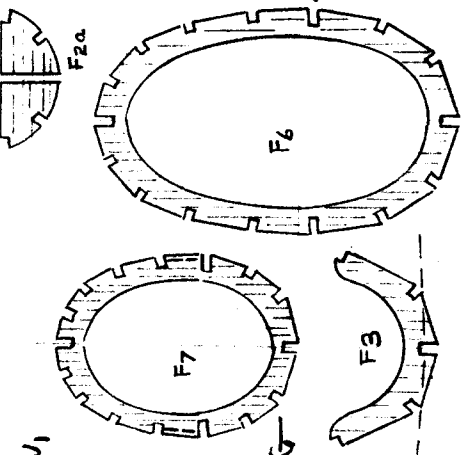
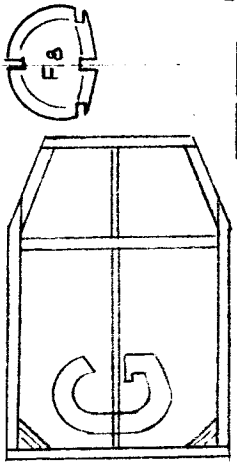

"G-EBDH" SAME POSITION ON BOTTOM SURFACE OF LOWER WING

STYROFOAM OR HOLLOWED OUT SOFT Balsa

SIDE VIEW

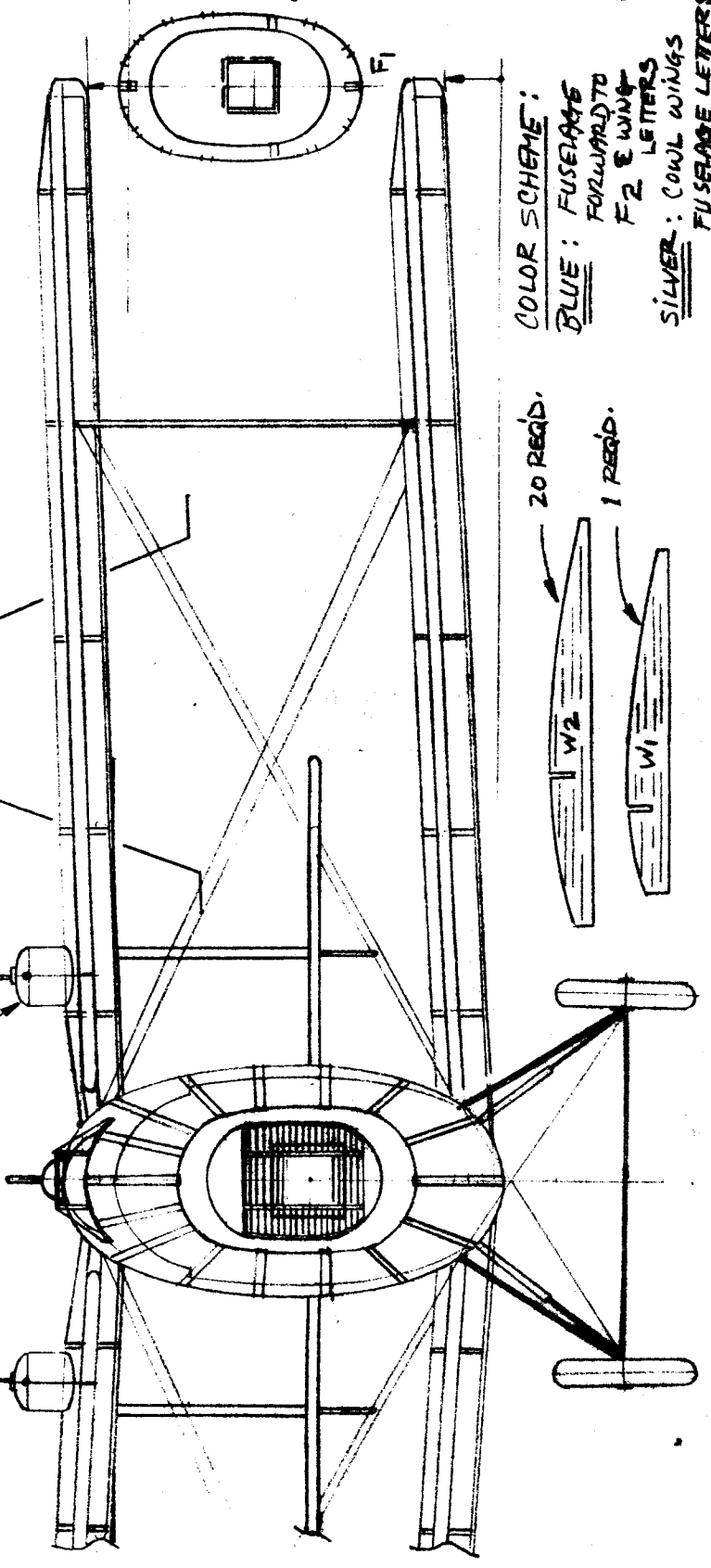
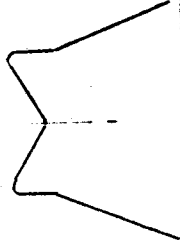

COLOR SCHEME:

BLUE: FUSELAGE FORWARD TO F2 & WING LETTERS

SILVER: COWL WINGS FUSELAGE LETTERS

20 REEDS



1 REED



# VICKERS VULCAN

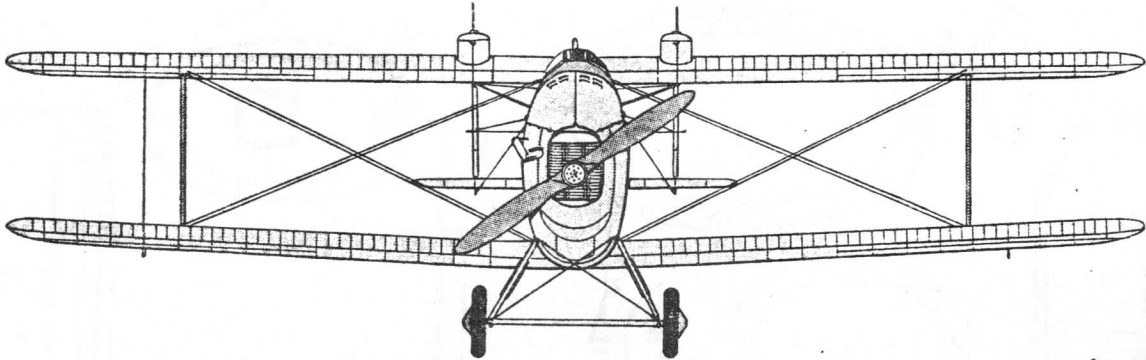

Type 61, G-EBDH of Instone Airline Ltd.

Aeroplane  
COPYRIGHT

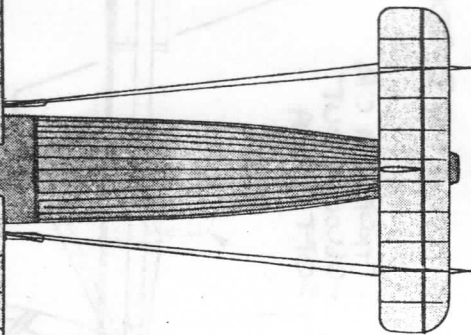
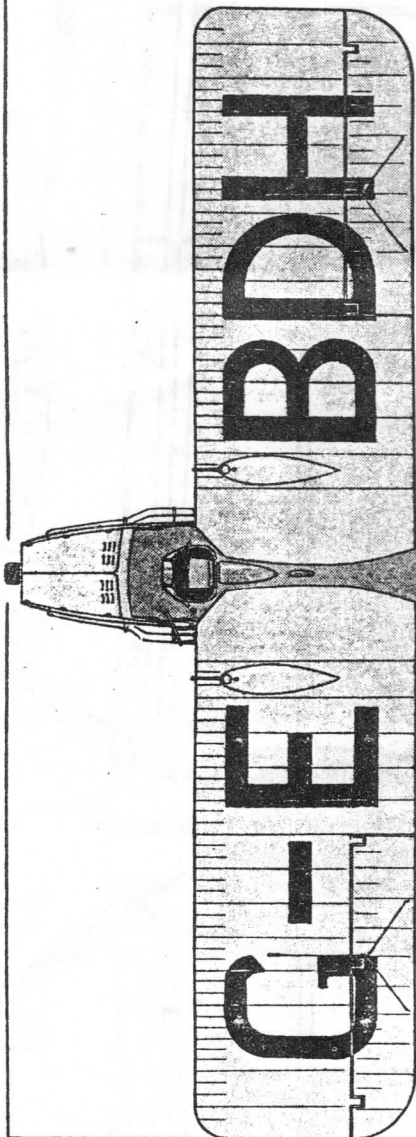
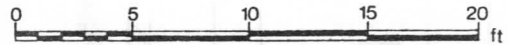
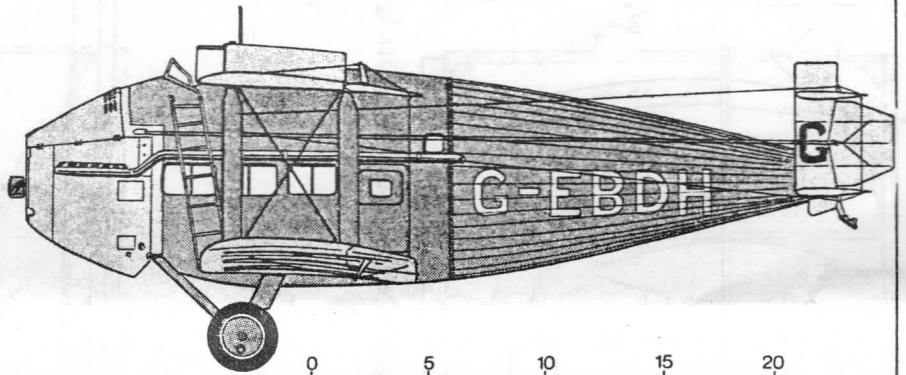

Instone Airline Ltd.

Type 74, G-EBLB of Imperial Airways,  
crashed at Purley on take off 13th July 1928.

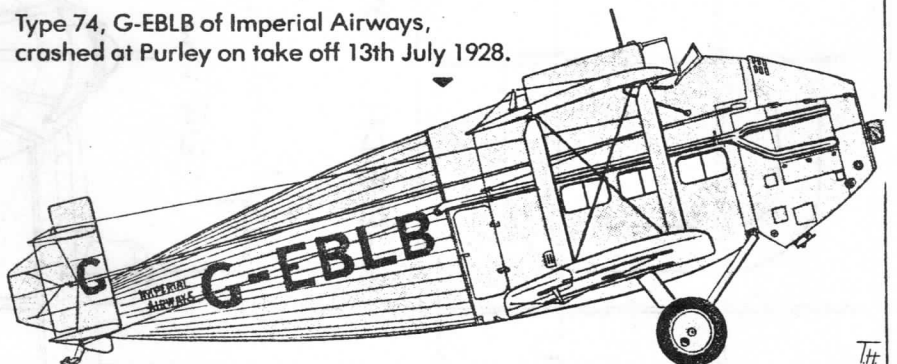

TH